



PIPE TOOLS & VISES  
SINCE 1896

Applies to: 02311, 02313

# Tripod Pipe Vises: Yoke Style (R40+)

## Replacement Parts

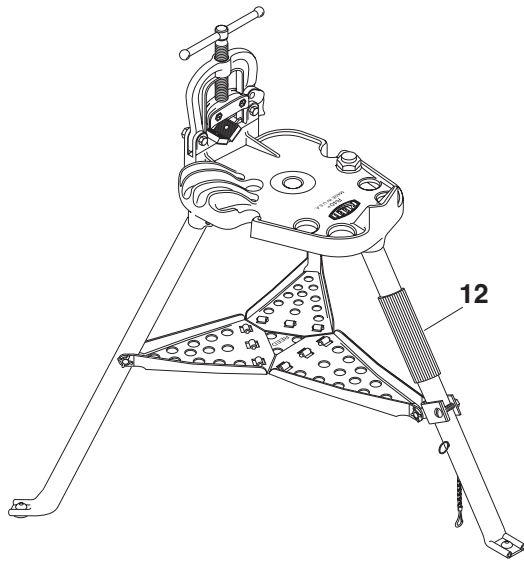

Capacity: 1/8" Through 2 1/2"

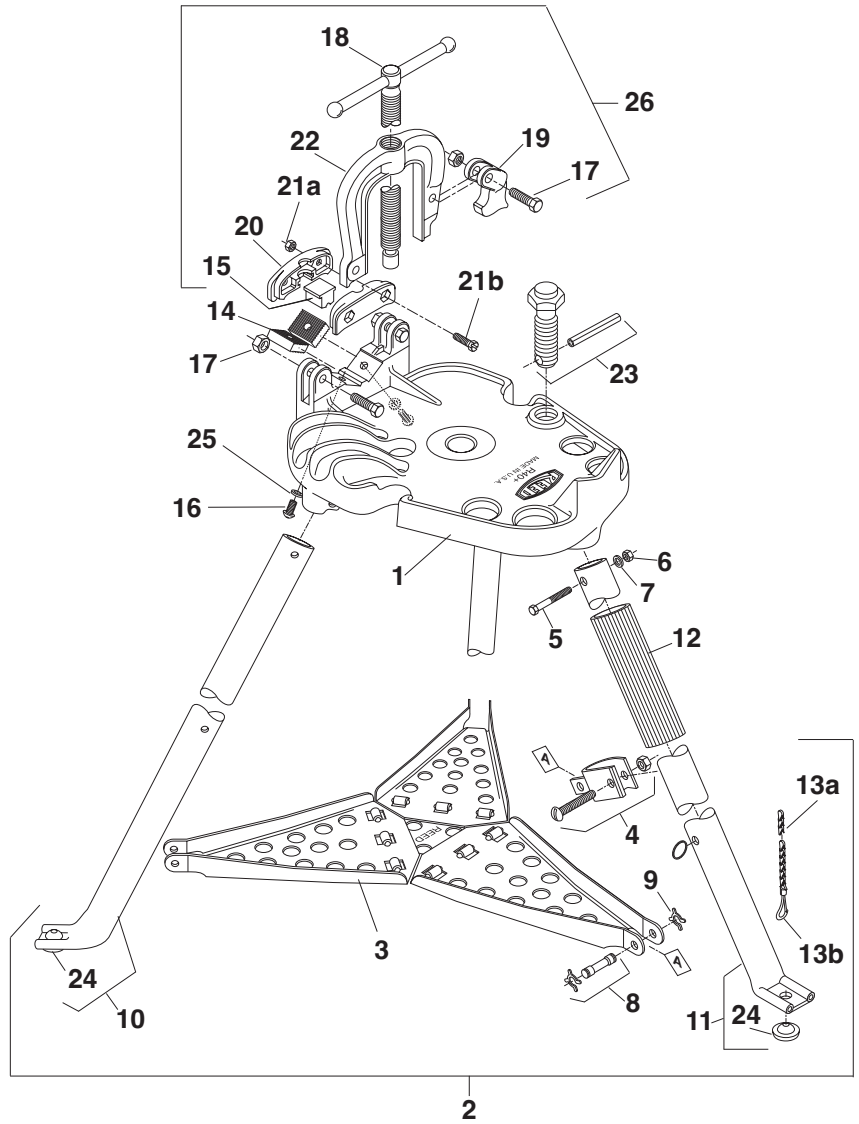

## Parts List

Ref. No.	Description	REED (pack) Item Code	REED Item Code	Replaces RIDGID®	
				Cat No.	Old P/N
1	Base		99003	NI	NI
2	Leg & Tray Assembly		99052	40915	B-2007-X
3	Tool Tray		99004	41240	C-448
4	Tray Support Clamp w/screw & nut		99054	41235	D-488-X
5	Leg Bolt (3)	5 Pk=99070	30187	46670	E-868
6	Nut (3)	5 Pk=99071	30032	44225	E-1094
7	Lock Washer (3)	5 Pk=99072	30033	40930	E-1095
8	Tray Pins (3) w/ "X" Washers (6)		99053	41265	E-1375-X
9	"X" Washers (6)	5 Pk=99073	99010	41270	E-1377
10	Front Leg Assembly (2)		99057	41255	E-1385-X
11	Rear Leg Assembly		99058	41250	E-1389-X
12	Handle Grip		40183	—	—
13a	Leg Chain Assembly		99055	40945	E-1444-X
13b	Chain Hook		40205	—	—

Ref. No.	Description	REED (pack) Item Code	REED Item Code	Replaces RIDGID®	
				Cat No.	Old P/N
14	Jaws Lower (2)		92422	NI	NI
15	Upper Jaw		92421	NI	NI
16	Jaw Screws (2)		30054	—	—
17	Yoke Cap Screw & Nuts		99066	NI	NI
18	Handle & Screw Assembly		92423	—	—
19	Hook		92036	NI	NI
20	Crosshead (2)		92424	NI	NI
21a	Nut (1)		30052	NI	NI
21b	Screw (1)		30054	NI	NI
22	Yoke		92034	NI	NI
23	Jack Screw Assembly		99064	41230	E-3207-X
24	Grommet (3)	5 Pk=99079	40171	40940	F-532
25	Jaw Screw Washer (2)		30033	—	—
26	Yoke Assembly		99068	NI	NI

NI - Not Interchangeable with Ridgid Tool Co. parts. © RIDGID is a registered trademark of Ridgid Tool Co.

Reed Manufacturing  
1425 West 8th Street  
Erie, PA 16502 USA



Phone: 800-666-3691 or +1-814-452-3691  
reedsales@reedmfgco.com  
www.reedmfgco.com

RP-0723-02  
#50440

# Tripod Pipe Vises: Yoke Style

## Operation & Instructions For Assembling Legs & Tray

All R40 models

Applies to: 02311, 02313

Patented

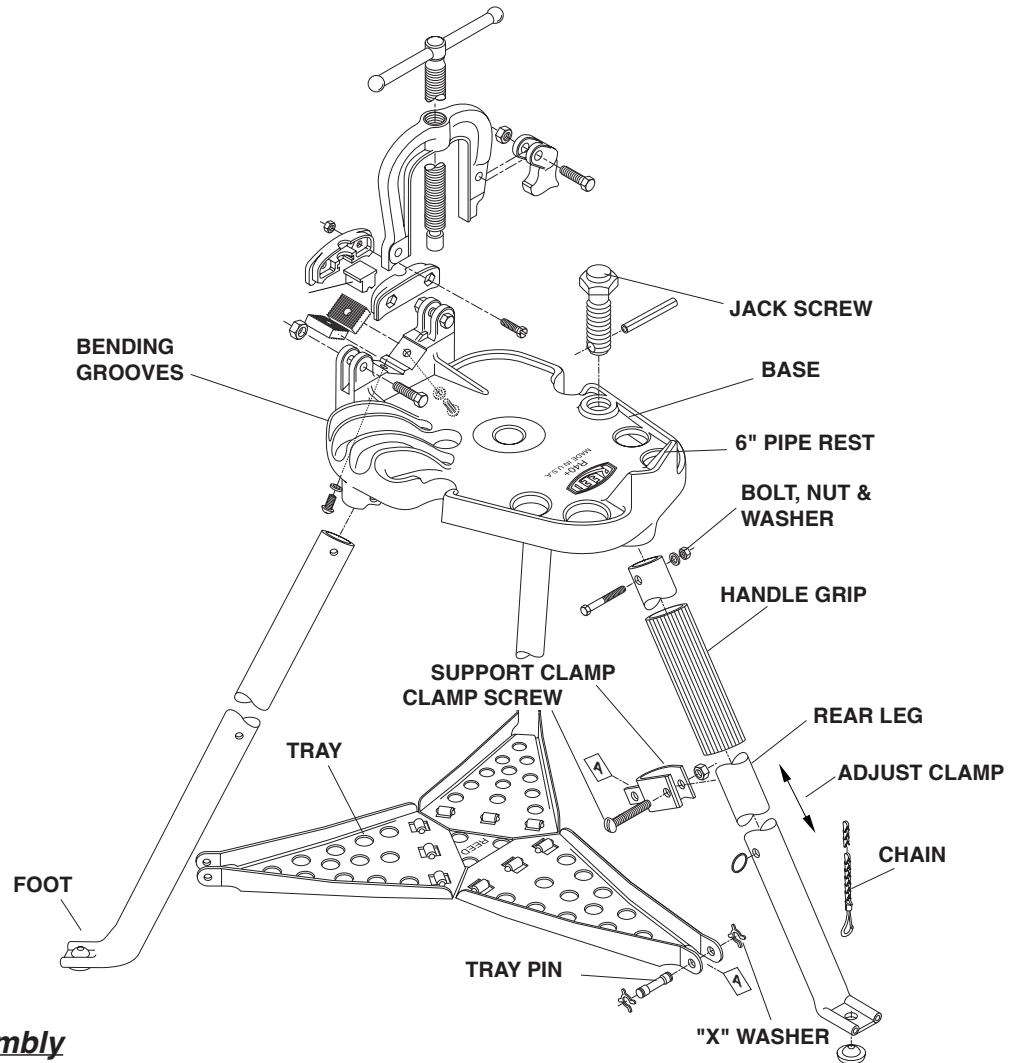

### Replacement Parts Assembly

- 1) For easier assembly, place the base upside down on a flat surface.
- 2) Insert rear leg in base with foot pointing outward as shown. Secure to base with bolt, nut, and washer. Tray support is pre-set with a clamp collar for approximate position and is adjustable. (see "Tray Adjustment" note below).
- 3) Insert front legs so feet are pointing outward and secure to base with bolts, washers, and nuts.
- 4) To assemble tray, open tray so that side of flanges are facing bottom of base. Attach the rear leg first with tray pin then proceed to front legs.
- 5) Push "X" washers in pin grooves and pinch long ends together with pliers.
- 6) Stand tripod on legs. If you have a yoke vise tripod, assemble yoke to base. The hook on the yoke can either be on the right or left side depending on operator.

### Operation and Maintenance

**JAWS** — To renew teeth—remove jaw screws and nuts, rotate jaws in either direction, replace jaw screws and nuts and tighten.

**TRAY ADJUSTMENT**— If folding tray does not snap into position and hold legs rigid when tripod is set up, loosen clamp screw in rear leg tray support and slide support clamp upward — tighten clamp screw securely.

**JACK SCREW** — Used with a length of 1" pipe as an adjustable ceiling brace to anchor tripod, but for large heavy pipe, fasten feet of tripod to floor securely.

**BENDERS** — Place pipe, conduit, or tubing into holes provided on base and pull down into grooves.

**HANDLE GRIP** — To install new handle grip over top of rear leg, insert compressed air hose nozzle under bottom edge and pull down while expanding with air flow.

**LUBRICATION** — Periodically lubricate the tray hinge, vise screw, jack screw, and chain with oil or spray silicone.