

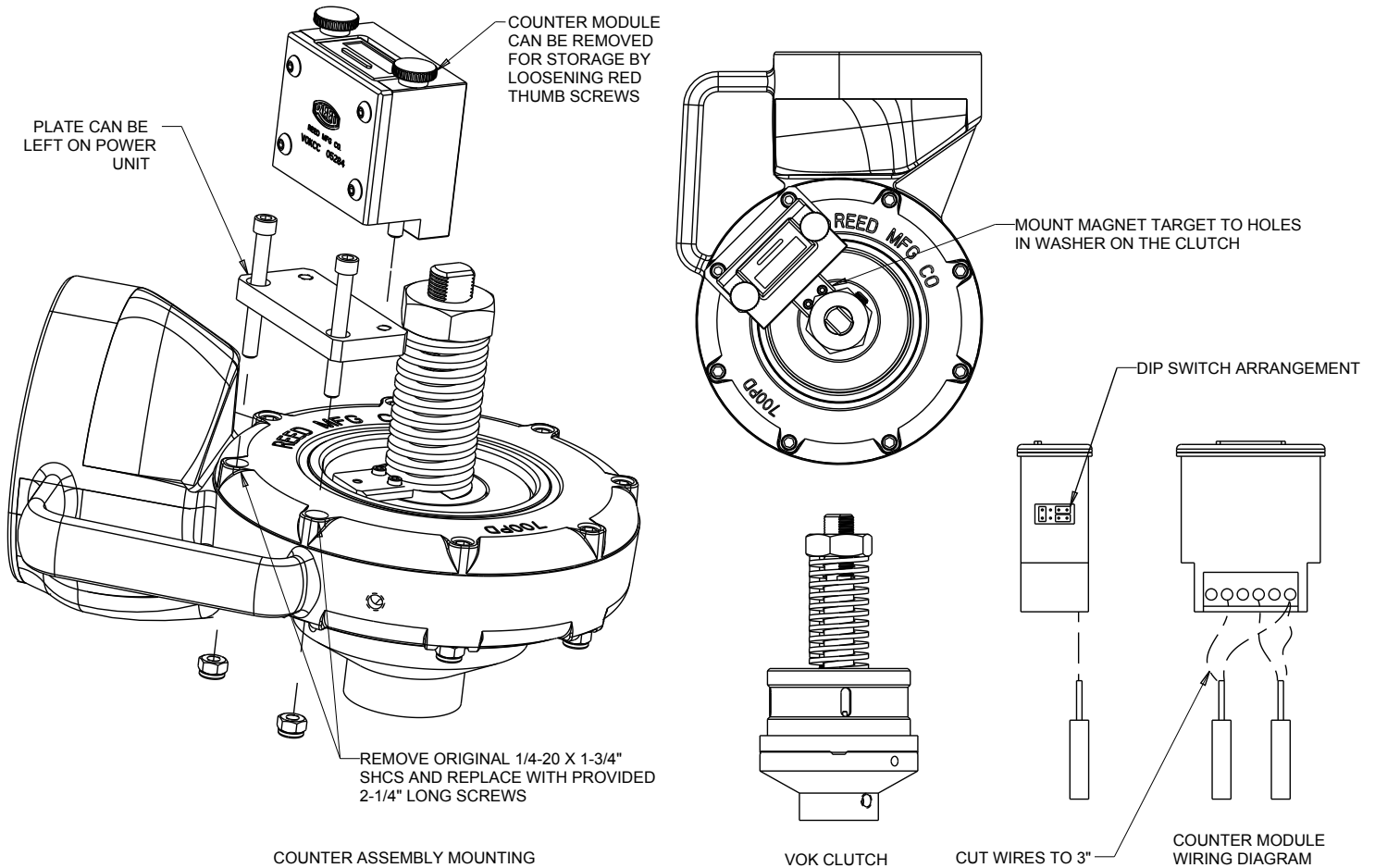

PIPE TOOLS & VISES
SINCE 1896

Valve Operator VOKCC with VOKCLUTCH & Counter

#05284



INSTALLATION INSTRUCTIONS

To mount the VOKCC VOK CLUTCH & COUNTER to the 700PD Power Drive first remove the 1/4-20 X 1-3/4" socket head cap screws and lock nuts from the 700PD as shown in the diagram. Remove the counter module from the base plate by loosening the two red thumb screws. Place the base over the two screw holes in the 700PD and replace the two 1/4-20 X 1-3/4" SHCS with the supplied 1/4-20 X 2-1/4" SHCS. Reattach the lock nuts and tighten. Remount the Counter module.

Mount the magnetic target to the washer on the clutch assembly and inset the clutch assembly into the 700PD.

OPERATING INSTRUCTIONS

The counter works by the magnet passing two sensors in the bottom of the counter module. When the 700PD Power Drive is run in a clockwise direction, the numbers on the counter will advance in a positive direction from 0 to 99999999. If the power drive is run in a counterclockwise direction, the numbers on the counter will advance in the opposite direction from 99999999 to 0. The counter is powered by an unreplaceable internal battery that has a 5 - 7 year life and the Counter Module #95289 will have to be replaced periodically.

The counter module is removable and can be stored separately in a safe place when not in use. The counter base plate can remain on the 700PD and should not interfere any other uses of the power drive.