



PIPE TOOLS & VISES
SINCE 1896

Catalog No. - SAWITVISE
Item Code #04600

Saw It® with Twist Throttle
Cat. No. - SAWIT
Item Code #07600

Saw It® with
Deadman Switch
Cat. No. SAWITD
Item Code #07610

Blades and
SAWITVISE
sold separately.

Operating Instructions

Saw It® Pneumatic Saw

The Reed Saw It® is a reciprocating pneumatic saw that cuts plastic, steel, stainless steel, and ductile iron pipe. Saw It® cuts up to 20" (500 mm) with a single setup.



WARNING!

**READ AND UNDERSTAND ALL INSTRUCTIONS.
FAILURE TO FOLLOW ALL INSTRUCTION LISTED
INSIDE MAY RESULT IN ELECTRIC SHOCK, FIRE,
AND/OR SERIOUS PERSONAL INJURY.**

SAVE THESE INSTRUCTIONS!

REED MANUFACTURING COMPANY

1425 WEST EIGHTH ST. ERIE, PA 16502 USA

PHONE: 800-666-3691 OR 814-452-3691 FAX: 800-456-1697 OR 814-455-1697

www.reedmfgco.com

Work Area

1. **Keep your work area clean and well lit.** Cluttered benches and dark areas invite accidents.
2. **Keep bystanders, children, and visitors away while operating a power tool.** Distractions can cause you to lose control.

Personal Safety

1. **Stay alert, watch what you are doing and use common sense when operating a power tool.** Do not use tool while tired or under the influence of drugs, alcohol, or medication. A moment of inattention while operating power tools may result in serious personal injury.

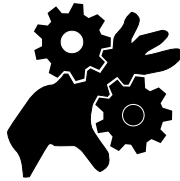

2. **Dress properly. Do not wear loose clothing or jewelry. Contain long hair.** Keep your hair, clothing and gloves away from moving parts. Loose clothes, jewelry, or long hair can be caught in moving parts.
3. **Avoid accidental starting.** Be sure the air supply to the tool is shut off before connecting to a source of pressurized air.
4. **Do not over reach. Keep proper footing and balance at all times.** Proper footing and balance enables better control of the tool in unexpected situations.
5. **Use safety equipment.** Always wear eye protection. Dust mask, non-skid safety shoes, and hard hat, must be used for appropriate conditions.



6. **Hearing protection** must be used.

Tool Use and Care

1. **Use clamps or other practical methods to secure and support the work piece to a stable platform.** Holding the work by hand or against your body is unstable and may lead to loss of control.
2. **Do not force the tool.** Use the correct tool for your application. The correct tool will do the job better and safer at the rate for which it is designed.
3. **Do not use the tool if the control valve does not turn the tool ON and OFF.** Any tool that cannot be controlled with a control valve is dangerous and must be repaired.
4. **Disconnect the air supply before making adjustments, changing accessories, or storing the tool.** Such preventive safety measures reduce the risk of starting the tool accidentally.
5. **Store idle tools out of reach of children and other untrained persons.** Tools are dangerous in the hands of untrained users.

6. **Maintain tools with care.** Keep cutting tools sharp and clean. Properly maintained tools with sharp cutting edges are less likely to bind and are easier to control.
7. **Check for misalignment or binding of moving parts, breakage of parts, and any other condition that may affect the tool's operation.** If damaged, have the tool serviced before using. Many accidents are caused by poorly maintained tools.
8. **Use only accessories that are recommended by the manufacturer for your model.** Accessories that may be suitable for one tool may become hazardous when used on another tool.

Service

1. **Tool service must be performed only by qualified repair personnel.** Service or maintenance performed by unqualified personnel could result in a risk of injury.
2. **When servicing a tool, use only identical replacement parts.** Follow instructions in the Maintenance section of this manual. Use of unauthorized parts may create a risk of injury.

Tool Safety

1. **The Saw It® is made to cut plastic, steel, stainless steel, and ductile iron pipe.** Follow these Operating Instructions on tool use. Other uses may increase the risk of injury.
2. **Always use a clamping device with the tool.** The Reed #04600 SAWITVISE resists forces developed while cutting and prevents losing control of the tool.
3. **Do not use dull or damaged blades.** Sharp cutting tools are less likely to bind and tool is easier to control.

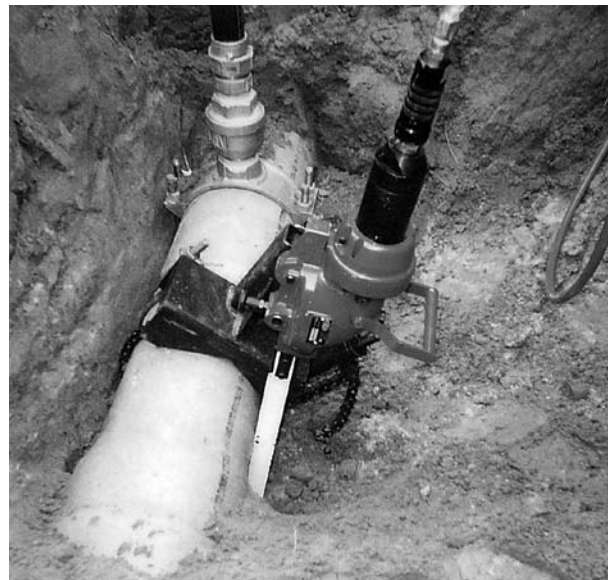

Functional Description

The Reed Saw It® is a pneumatic reciprocating saw that provides power for cutting plastic, steel, stainless steel, and ductile iron pipe.

Specifications/Standard Equipment

Cutting Capacity depends on blade type and length. Use blades at least six inches longer than outside diameter of the pipe being cut. Use finer pitch blades on thinner walls. A useful rule of thumb: Keep three blade teeth engaged at all times.

For speed, straightness of cut, long life and safety, bimetal blades are the best choice for the Reed Saw It® and Heavy Duty Power Hack Saws made by Widder®, Fein®, and Spitznas®. Blades cut, steel, stainless steel, aluminum, harder plastics like PVC, copper, ABS.



Cat. No.	Item Code	Length/Width/Thickness		Teeth Per Inch	Std. Pkg.
		Inches-Nom.	mm		
Z1214	04494	12 x 1 ³ / ₈ x .062	300 x 35 x 1.6	14	10
Z1614	04495	16 x 1 ³ / ₈ x .062	400 x 35 x 1.6	14	10
Z2114	04496	21 x 1 ³ / ₈ x .062	533 x 35 x 1.6	14	10
Z2414	04497	24 x 1 ³ / ₈ x .062	600 x 35 x 1.6	14	10
Z3014	04498	30 x 1 ³ / ₈ x .062	760 x 35 x 1.6	14	10
Z1608	04499	16 x 1 ³ / ₈ x .062	400 x 35 x 1.6	8	10
Z1014	04479	10 x 1 ³ / ₈ x .062	250 x 35 x 1.6	14	10
Z2108	04597	21 x 1 ³ / ₈ x .062	533 x 35 x 1.6	8	10
Z814	04478	8 x 1 ³ / ₈ x .062	200 x 35 x 1.6	14	10

Motor, Gears, and Speed - 07600

90 psig design operating pressure
1.5 horsepower
0 - 300 rpm
Stroke length - 2 13/32, 61 mm
Air Consumption 50 cfm
Tool Weight 17 lbs. (7.7 Kg)
Tool measures 22" x 7" x 5"
Vise Weight 14 lbs. (6.4 Kg)
Vise measures 12 1/2" x 10" x 5"

Models 07610 & 07615

Same
Same
Same
Same
19 lbs. (8.6 Kg)
26" x 7" x 5"
Same
Same

Table:1

Recommended coolants and speeds

Material	Coolant	Speed (strokes/min)
Carbon and Alloy Steel	Mineral and Soluble Oil	300
Aluminum and Brass	Soluble Oil	300
Cast Iron	Water	250
Stainless Steel	Soluble Oil	150

Operating Instructions

WARNING:

- Operator should be thoroughly familiar with safety information before attempting to operate this equipment.
- When cutting, use Reed's #04600 SAWITVISE to hold

the tool against the material being cut. Not doing so can cause serious injury should the blade break or jam in the material.

- Blades are made of high speed steel and can fracture and break if used improperly. Ensure blades are sharp, ensure there exists ample side and forward clearance, and bring the tool up to speed slowly to avoid shock to blade.
- Remove nuts and plate from the Rail.
 - Attach blade.
 - Reinstall plate and nuts.
 - Attach SAWITVISE (#04600) to material/pipe.
 - Mount Saw It® to the vise by pulling plunger knob and sliding over vise shaft.
 - Connect air supply.
 - Apply coolant as needed.
 - Rotate knurled handle to turn on air. Bring tool up to speed slowly.
 - Rotate knurled handle in opposite direction to shut off air upon completion of cut.

USE A FILTER-REGULATOR-LUBRICATOR (FRL) UNIT.

It is imperative that a filter, regulator, lubricator be employed when running the Saw It®. Pneumatic motors are sensitive to contamination and are subject to wear, rust and sludge if not maintained properly. They require clean air and proper lubrication. Reed does not supply this unit with a Filter-Regulator-Lubricator. Reed FRL #97591 is sold separately. The FRL includes a stand and the unit is specifically tailored to the needs of the Saw It's high speed motor.

USE NONFLUID OIL® AIR LUBRICANT.

This product mixes with water inside the line and via the lubricator is introduced as a mist in the air stream to provide lubrication fairly quickly. Set the Oiler drip on the lubricator to 3-4 drops per minute. Nonfluid lubricating oil is sold by the quart from Reed as UPOIL #97583.

Adjust Filter, Regulator, Lubricator

- Before pressurizing, fill the oiler with Nonfluid oil by removing the black cap on the top. (Do not exceed the maximum fill line.) Replace cap.
- Set air pressure on the regulator to 90 PSI maximum. Loosen wing-nut on bottom of regulator, and turn large knob clockwise until pressure is attained.
- Set the Oiler drip on the lubricator to 3-4 drops per minute.

Maintenance

Warning: Disconnect air supply before servicing.

Note: Filtered and oiled air will allow the saw to operate more efficiently and parts will last longer.

- After every 40 hours of operation: Flush the air motor with a solution of three (3) parts cleaning solvent and one (1) part light oil. After flushing, pour about a teaspoon of spindle oil in the air outlet and run for two (2) minutes.
- After every 100 hours of operation: Remove #97653 End Cover and repack with grease.
- After every 500 hours of operation or annually: Disassemble the tool, clean, grease and oil.



PIPE TOOLS & VISES
SINCE 1896

Saw It® (SAWIT model)

Replacement Parts

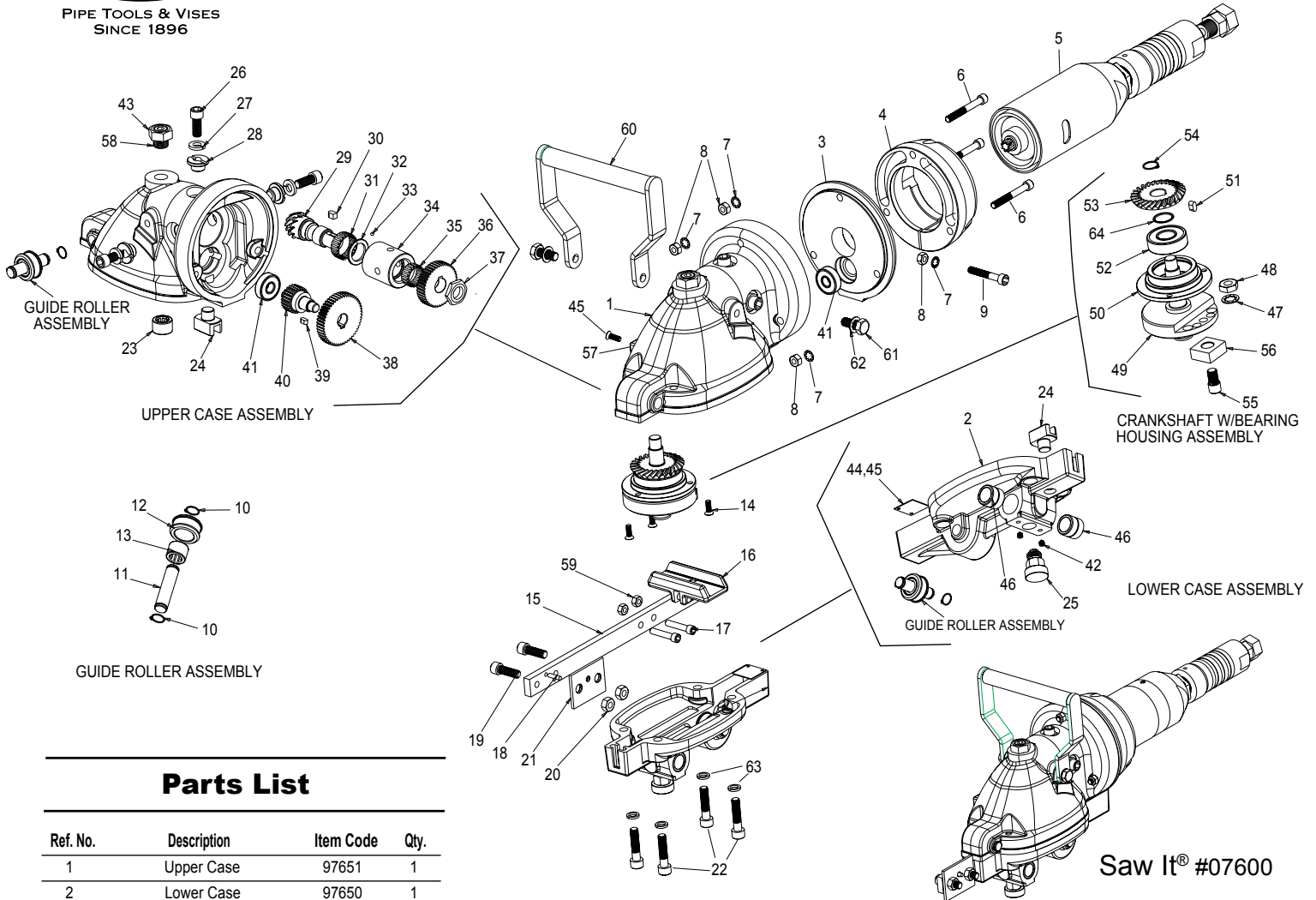

Parts List

Ref. No.	Description	Item Code	Qty.
1	Upper Case	97651	1
2	Lower Case	97650	1
3	End Cover	97653	1
4	End Clamp	97652	1
5	Air Motor Assembly	97730*	1
6	Bolt, SHCS	37667	3
7	Lock Washer	37655	4
8	Hex Nut	37650	4
9	Bolt, SHCS	37666	1
10	Snap Ring	47668	4
11	Guide Shaft	97670	2
12	Guide Roller	97668	2
13	Needle Bearing	47673	2
14	Screw, FHCS	37669	3
15	Rail	97676	1
16	Cam Bracket	97654	1
17	Bolt, SHCS	30302	2
18	Dowel Pin	37659	1
19	Bolt, SHCS	37671	2
20	Nut, Hex	30176	2
21	Clamp Plate	97666	1
22	Bolt, SHCS	37652	4
23	Needle Bearing	47674	1

Ref. No.	Description	Item Code	Qty.
24	Guide Bearing	97671	2
25	Spring Plunger	97678	1
26	Socket Head Cap Screw	32910	3
27	Lock Washer	37657	3
28	Offset Washer	97667	3
29	Gear Shaft	97660	1
30	Shaft Key	37660	1
31	Needle Bearing	47671	1
32	Thrust Washer	37658	1
33	Ball Bearing	37663	22
34	Bearing Housing	97675	1
35	Needle Bearing	47672	1
36	Spur Gear	97662	1
37	Jam Nut	37654	1
38	Helical Gear	97664	1
39	Shaft Key	37662	1
40	Reduction Gear	97663	1
41	Radial Bearing	47670	2
42	Flathead Screw	37673	2
43	Jam Nut	30058	1
44	Cover Plate	97677	1

Ref. No.	Description	Item Code	Qty.
45	Drive Pin	37710	4
46	Handle Bushing	97672	2
47	Lock Washer	37656	1
48	Jam Nut	37653	1
49	Crank Assembly	97674	1
50	Bearing Retainer	97673	1
51	Shaft Key	37661	1
52	Bearing	47669	1
53	Bevel Gear	97661	1
54	Snap Ring	47667	1
55	Bolt, SHCS	97681	1
56	Crank Bearing	97669	1
57	Name Plate	97680	1
58	Set Screw	37739	1
59	Hex Nut	37674	2
60	Bridge Type Handle	97750	1
61	Hex Bolt	37741	2
62	Lock Washer	37742	2
63	Lock Washer	37754	4
64	Internal Retaining Ring	47686	1

*See side 2 for 97730 parts

Saw It® #07600



PIPE TOOLS & VISES
SINCE 1896

Saw It® Air Motor

Replacement Parts

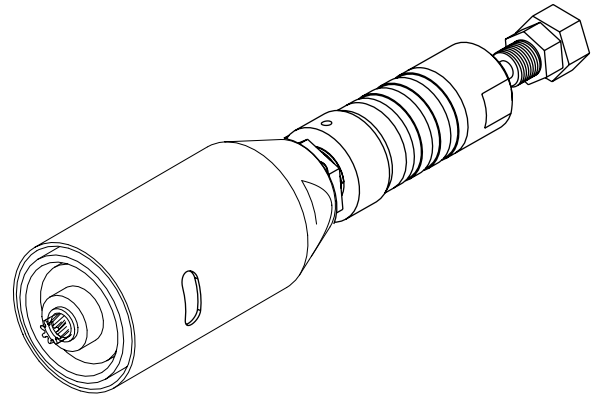
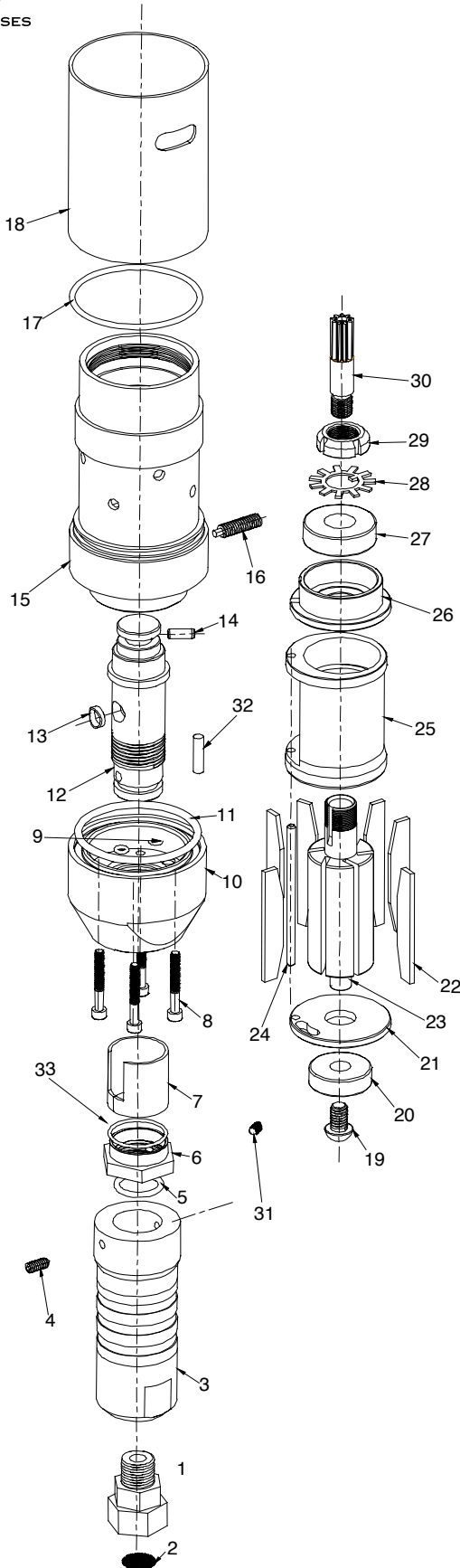

Parts List

Ref. No.	Description	Item Code	Qty.
1	Swivel Fitting	97727	1
2	Air Inlet Screen	97723	1
3	Lower Housing	97695	1
4	Socket Set Screw	37748	2
5	O-Ring AS-116	37750	1
6	Packing Gland Nut	37743	1
7	Packing	47659	1
8	1 1/4" Cap Screw	37746	4
9	O-Ring AS-007	37747	4
10	Coupling Housing	97696	1
11	O-Ring SA-227	37749	1
12	Fitting Housing	97697	1
13	O-Ring 022	37752	1
14	Dowel Pin	37753	1
15	Upper Housing	97694	1
16	Socket Set Screw	37744	1
17	O-Ring A-141	97709	1
18	Deflector Tube	97721	1
19	Button Head Screw	97719	1
20	Bearing Rotor	98846	1
21	Endplate	97716	1
22	Vane	97714	6
23	Rotor	97713	1
24	Dowel Pin	37720	1
25	Rotor Housing Cylinder	97712	1
26	Output Shaft Endplate	97715	1
27	Rotor Bearing	97717	1
28	Nut Retainer	37723	1
29	Bear Hug Nut	37722	1
30	Motor Spline	97665	1
31	Set Screw	37751	1
32	Dowel Pin	37745	1
33	O-Ring	37752	1



PIPE TOOLS & VISES
SINCE 1896

Saw It® (SAWITD & SAWITSD models)

Replacement Parts

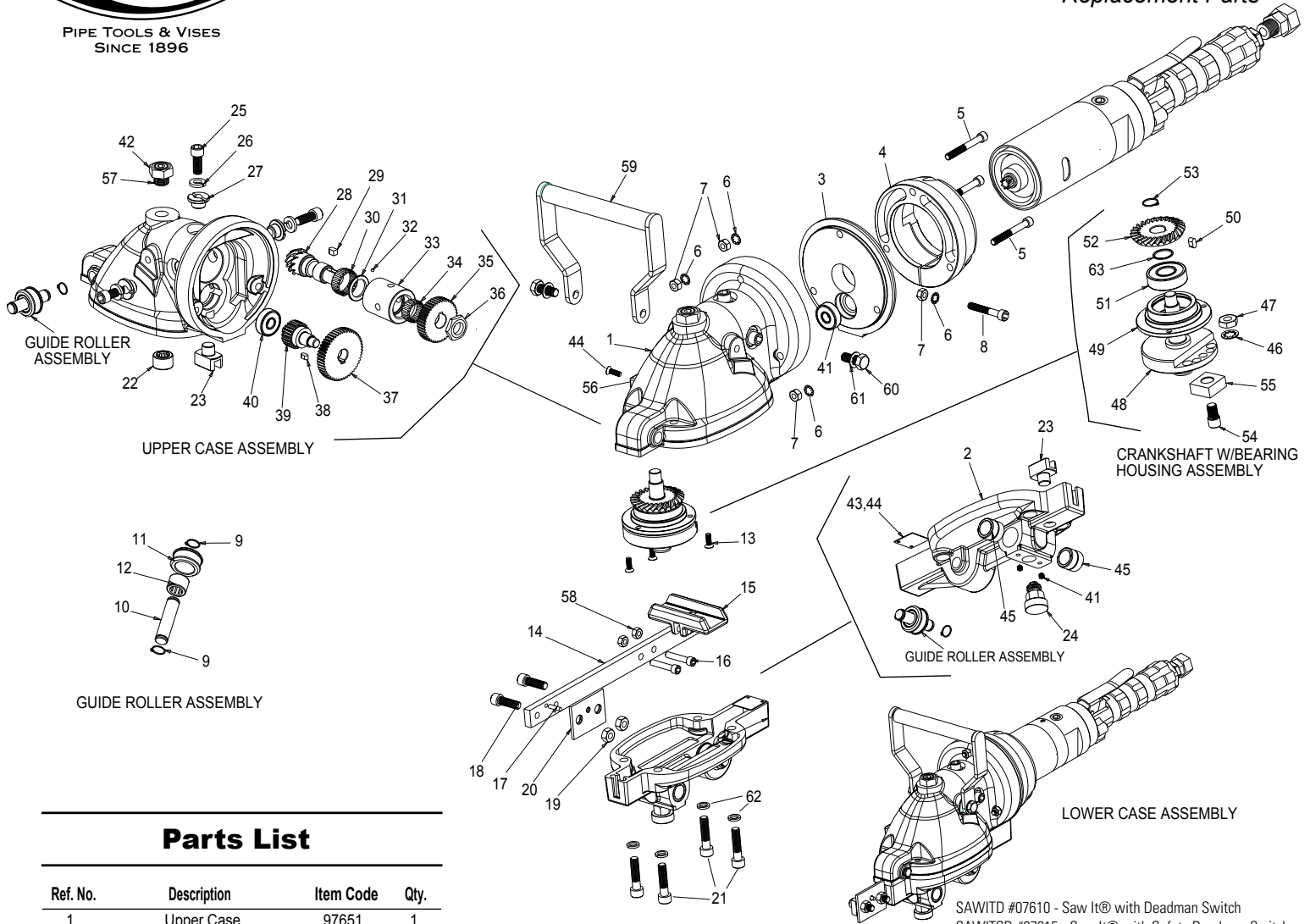

Parts List

Ref. No.	Description	Item Code	Qty.
1	Upper Case	97651	1
2	Lower Case	97650	1
3	End Cover	97653	1
4	End Clamp	97652	1
5	Bolt, SHCS	37667	3
6	Lock Washer	37655	4
7	Hex Nut	37650	4
8	Bolt, SHCS	37666	1
9	Snap Ring	47668	4
10	Guide Shaft	97670	2
11	Guide Roller	97668	2
12	Needle Bearing	47673	2
13	Screw, FHCS	37669	3
14	Rail	97676	1
15	Cam Bracket	97654	1
16	Bolt, SHCS	30302	2
17	Dowel Pin	37659	1
18	Bolt, SHCS	37671	2
19	Nut, Hex	30176	2
20	Clamp Plate	97666	1
21	Bolt, SHCS	37652	4
22	Needle Bearing	47674	1

Ref. No.	Description	Item Code	Qty.
23	Guide Bearing	97671	2
24	Spring Plunger	97678	1
25	Socket Head Cap Screw	32910	3
26	Lock Washer	37657	3
27	Offset Washer	97667	3
28	Gear Shaft	97660	1
29	Shaft Key	37660	1
30	Needle Bearing	47671	1
31	Thrust Washer	37658	1
32	Ball Bearing	37663	22
33	Bearing Housing	97675	1
34	Needle Bearing	47672	1
35	Spur Gear	97662	1
36	Jam Nut	37654	1
37	Helical Gear	97664	1
38	Shaft Key	37662	1
39	Reduction Gear	97663	1
40	Radial Bearing	47670	2
41	Flathead Screw	37673	2
42	Jam Nut	30058	1
43	Cover Plate	97677	1

Ref. No.	Description	Item Code	Qty.
44	Drive Pin	37710	4
45	Handle Bushing	97672	2
46	Lock Washer	37656	1
47	Jam Nut	37653	1
48	Crank Assembly	97674	1
49	Bearing Retainer	97673	1
50	Shaft Key	37661	1
51	Bearing	47669	1
52	Bevel Gear	97661	1
53	Snap Ring	47667	1
54	Bolt, SHCS	97681	1
55	Crank Bearing	97669	1
56	Name Plate	97680	1
57	Set Screw	37739	1
58	Hex Nut	37674	2
59	Bridge Type Handle	97750	1
60	Hex Bolt	37741	2
61	Lock Washer	37742	2
62	Lock Washer	37754	4
63	Internal Retaining Ring	47686	1

*See side 2 for 97674 parts

See also RP-1210-107



PIPE TOOLS & VISES
SINCE 1896

Saw It® Air Motor

Replacement Parts

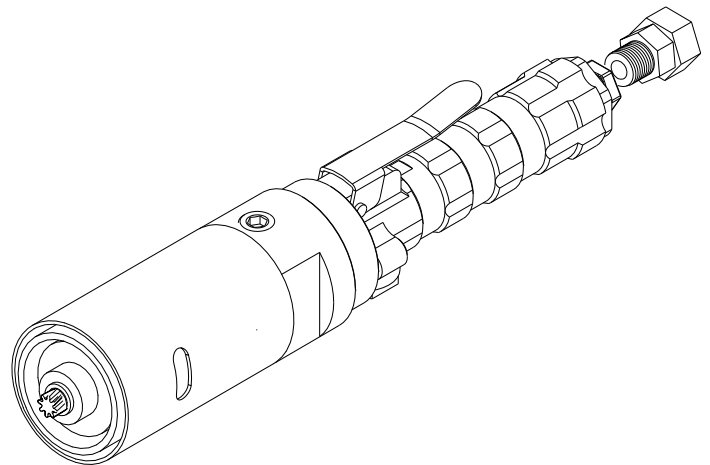
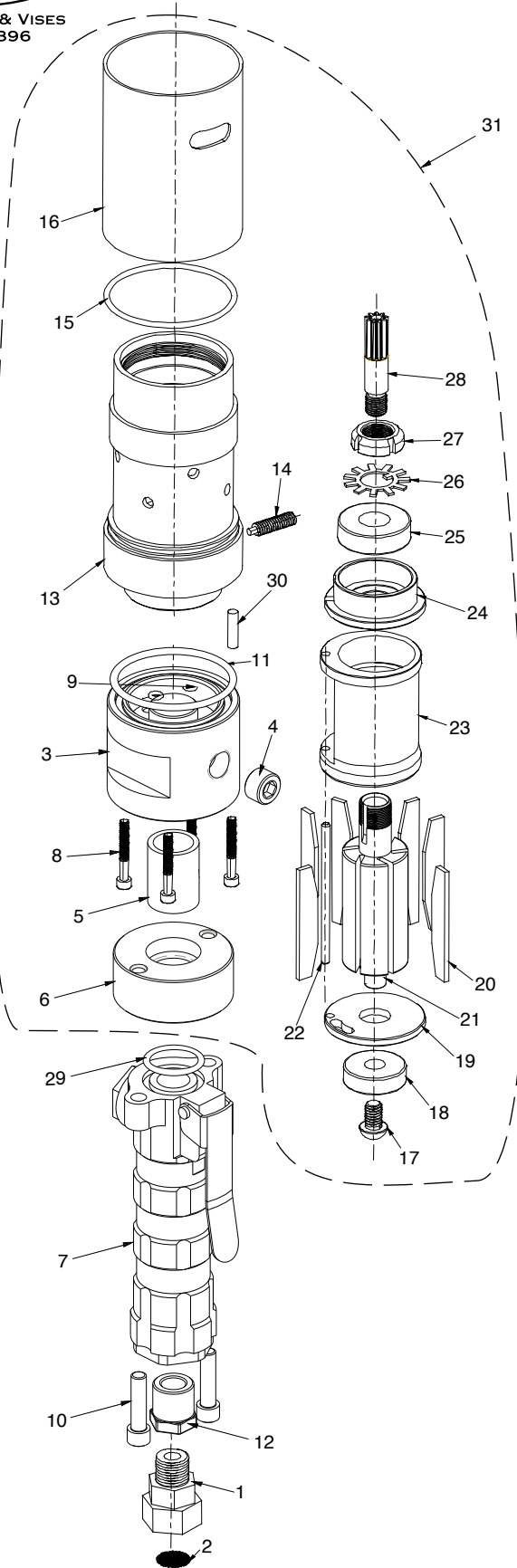

Parts List

Ref. No.	Description	Item Code	Qty.
1	Swivel Fitting	97727	1
2	Air Inlet Screen	97723	1
3	Coupling Housing	97685	1
4	Plug	37726	1
5	Pipe Nipple	37725	1
6	Handle Adapter	97686	1
7a	Lever Handle, Deadman	47683	1
7b	Lever Handle, Safety Deadman	47684	1
8	1 1/4" Cap Screw	37746	4
9	O-Ring AS-007	37747	4
10	Socket Head Cap Screw	30241	2
11	O-Ring SA-227	37749	1
12	Bushing	37727	1
13	Upper Housing	97694	1
14	Socket Set Screw	37744	1
15	O-Ring A-141	97709	1
16	Deflector Tube	97721	1
17	Button Head Screw	97719	1
18	Bearing Rotor	98846	1
19	Endplate	97716	1
20	Vane	97714	6
21	Rotor	97713	1
22	Dowel Pin	37720	1
23	Rotor Housing Cylinder	97712	1
24	Output Shaft Endplate	97715	1
25	Rotor Bearing	97717	1
26	Nut Retainer	37723	1
27	Bear Hug Nut	37722	1
28	Motor Spline	97665	1
29	O-Ring	37738	1
30	Dowel Pin	37745	1
31	Air Motor Assembly	97684	1



Reed Lifetime Warranty

Reed Hand Tools are for the professional trade and are warranted against all failure due to defects in workmanship and materials for the normal life of the tool.

FAILURES DUE TO MISUSE, ABUSE, OR NORMAL WEAR AND TEAR ARE NOT COVERED BY THIS WARRANTY.

Power units for Universal Pipe Cutters, Saw It[®], electric test pumps, and threading power drives are warranted for a period of one year from date purchased.

NO PARTY IS AUTHORIZED TO EXTEND ANY OTHER WARRANTY. NO WARRANTY FOR MERCHANTABILITY OR FITNESS FOR A PARTICULAR PURPOSE SHALL APPLY.

No warranty claims will be allowed unless the product in question is received freight prepaid at the Reed factory. All warranty claims are limited to repair or replacement, at the option of the company, at no charge to the customer. REED IS NOT LIABLE FOR ANY DAMAGE OF ANY SORT, INCLUDING INCIDENTAL AND CONSEQUENTIAL DAMAGES. Some states do not allow the exclusion or limitation of incidental or consequential damages, so the above exclusion may not apply.

This warranty gives you specific legal rights, and you may also have other rights which vary from state to state.



PIPE TOOLS & VISES
SINCE 1896

REED MANUFACTURING COMPANY

1425 WEST EIGHTH ST. ERIE, PA 16502 USA

PHONE: 800-666-3691 OR 814-452-3691 FAX: 800-456-1697 OR 814-455-1697

www.reedmfgco.com