



CDTM1000/CDTM2000

OWNER'S MANUAL

Operation, Maintenance and Service Instructions

attention:

Read and fully understand instructions before operating the TM1000 tapping machine or the DM1000 drilling machine. It is essential to properly train and review with operating personnel to prevent possible bodily injury and property damage. It is advantageous to practice drilling a piece of pipe to acquaint personnel with the machine. (See section V part F).

CONTENTS:

- 1) Basic Product Information
- 2) Necessary Accessories
- 3) Conversion Instructions
- 4) TM1000 Operating and Maintenance Instructions
- 5) DM1000/DM2000 Operating and Maintenance Instructions
- 6) Parts Illustration & List
- 7) New Drilling Applications Sheet

REED MANUFACTURING COMPANY

1425 West 8th Street - P.O. Box 1321

Erie, Pennsylvania 16512 U.S.A.

Phone: (800) 666-3691 or (814) 452-3691

Fax: (800) 456-1697 or (800) 455-1697

Part #50391

TAPPING MACHINE - TM1000 DRILLING MACHINE - DM1000, DM2000 COMBINATION TAPPING & DRILLING MACHINE - CDTM1000, CDTM2000

Basic Product Information

The TM1000 tapping machine is used to drill and tap water mains while under pressure, then installs the 3/4" or 1" corporation stops in a 2 step operation. It covers a range of 4"-48" cast or ductile iron and C-900 PVC with the use of saddles and chain extensions. It utilizes the Reed DT series drill-taps.

The DM1000 and DM2000 drilling machines drill through the pipe wall via the corporation stop inserted into the service saddle while under pressure. It utilizes Reed D series drills, and hole saws.

The CDTM1000 and CDTM2000 combination machines uses common components to assemble either the drilling machine or the tapping machine. It utilizes Reed DT series drill-taps and Reed D series drills and hole saws.

Catalog No.	Item Code	Size	Pipe Dia	Shipping Wt
TM1000	08400	3/4" - 1"	4"-48"	110 lbs
DM1000	08402	3/4" - 1"	N/A	45 lbs est
DM2000	08412	3/4" - 2"	N/A	50 lbs est
CDTM1000	08404	3/4" - 1" Drill and Tap,	N/A	120 lbs est
CDTM2000	08414	3/4" - 1" Tap, 3/4"-2" Drill	N/A	125 lbs est

Additional Specifications

- Tool Box overall outside dimensions, TM1000 27 5/8 x 13 3/4 x 14, DM1000 23 x 10 1/2 x 11 3/8. see sketch for overall machine dimensions.
- Machine Clearance radius TM1000 = 32". DM1000 = 26" .
- **Pressure Rating:** Design pressure rating for valve and chamber = 250 psi.
- Operating Pressure Rating - 90 psi - ie - Drilling or Tapping into pressurized mains.

Warning:

Drilling or Tapping into highly pressurized mains is not recommended. However, it is permissible at pressure up to 250 psi if utilizing special precautions and incorporating high pressure attachments such as the Mueller® Power Clevis #H-10800. (See operations and maintenance manual.)

Do NOT use on natural gas or petroleum piping.

- Flushing/blow by port: 1/2-14 NPT plugged port is provided in bottom chamber for flushing chips while tapping into pressurized mains.
 - Operation and maintenance - Pages 4-7
 - Swing check valve resists clogging and is easier to clean out.
 - Manual pressure balancing, and top chamber pressure relief valves are accessible and easy to use.
 - Manual or power drive operation through 13/16" square shaft. Power drive adapter optional.
 - Materials and finish
 - A) Hard anodized and powder epoxy painted aluminum frames.
 - B) Alloy steel boring bar.
 - C) Heavy duty steel chain and forged steel chain hooks.
 - D) Bronze and zinc aluminum parts.
 - E) EPR rubber gaskets and "O" rings.
 - TM1000 uses standard Reed DT series as well as other manufacturer's drill-taps.
 - The DM1000 and DM2000 use standard Reed D series drills and drill adapters, as well as other manufacturer's drills and drill adapters.
- ® Registered Trademark of Mueller Company.

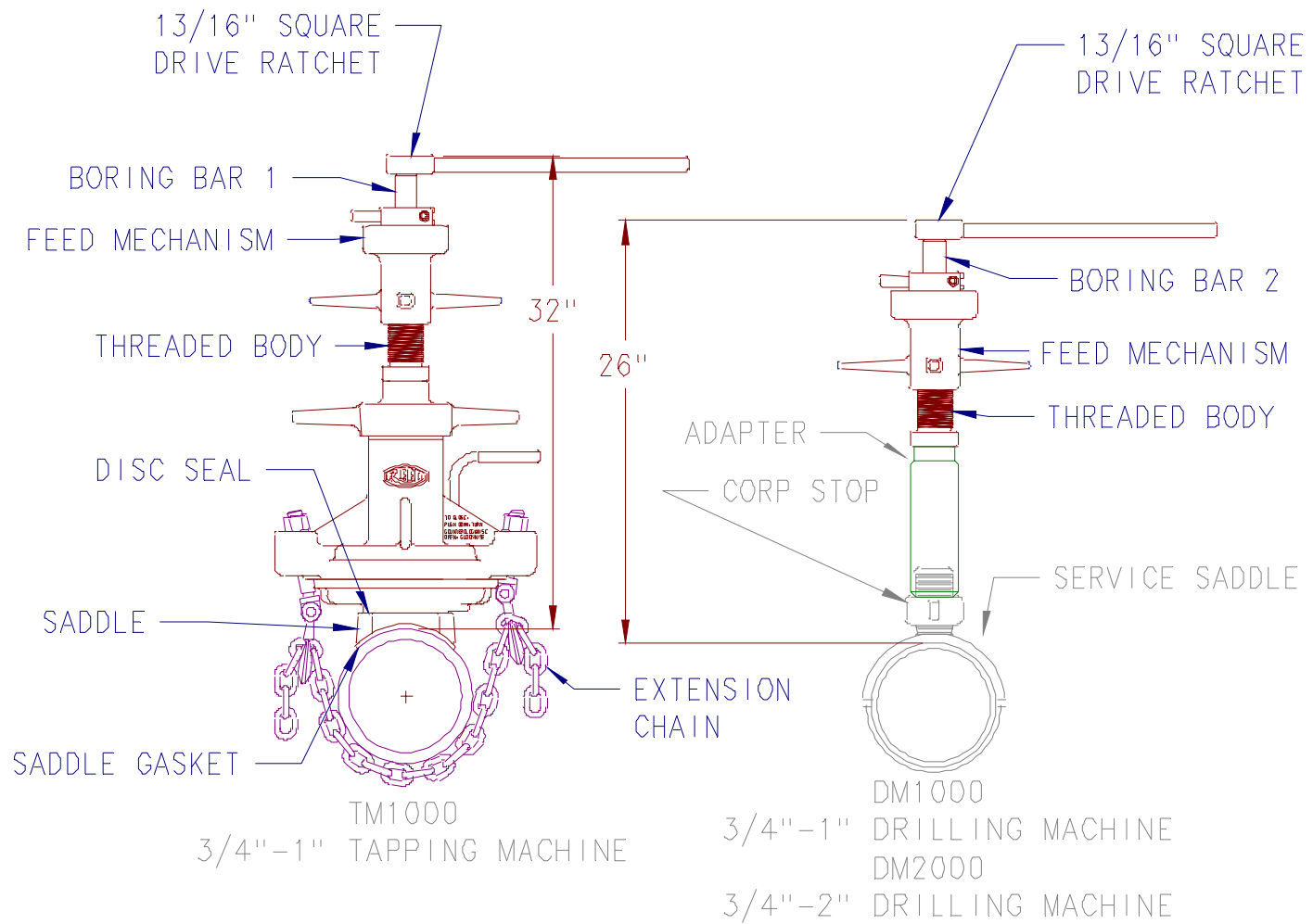

TM1000 Necessary Accessories

DESCRIPTION	CATALOG NO.	ITEM CODE
Saddles		
Saddle 4" **	TS4	20542
Saddle 6" **	TS6	20539
Saddle 8" **	TS8	20540
Saddle 10" **	TS10	20541
Saddle 12" **	TS12	20538
Saddle 16" **	TS16	20543
Saddle 18" **	TS18	20544
Saddle 20" **	TS20	20545
Saddle 24" **	TS24	20546
Saddle 30-36" **	TS30	20547
Saddle 42" **	TS42	20548
Saddle 48" **	TS48	20549
Drill Taps		
Drill Tap 3/4" **	DT75	04390
Drill Tap 1" **	DT100	04391
Drill Tap 3/4" PVC **	DT75P	04396
Drill Tap 1" PVC **	DT100P	04397
Corp Stop Tools		
* 3/4" Corp Insertion Tool **	CIT75	98423
* 1" Corp Insertion Tool **	CIT100	98424
* Adapter Shank **	TMAS	98422
Miscellaneous		
* Ratchet Handle 13/16" Sq. **	RWR1316	40383
Power Drive Adapter	TMPDA	08430
* Chain 5' Lg	CX5	98417
Chain Clevis 5/16"	CC516	40394
* Tapping Compound **	TMTC	98425
* Saddle Gasket **	TMSG	40372
* Sealing Disc **	TMSD	40371
* Bearing Sleeve **	TMBS	98411
* Knockout Pin **	TMKP	98412
* Operators Manual	TMIM	50387

* - Standard with TM1000 machine.

** - Interchangeable with equivalent B100/B101 machine parts.

DM1000/DM2000/DMBASE Necessary Accessories

DESCRIPTION	CATALOG NO.	ITEM CODE
Drill Adapters		
** Drill Adapter 3/4" (1)	DA75	98461
** Drill Adapter 1" (2)	DA100	98462
Drill Adapter - PVC (3)	DMAPVC	94150
*** Hole Saw Adapter (4)	DMHSA	08413
Drills/Hole Saws		
11/16" Drill (For D.I., C.I.)	D688	04380
7/8" Drill (For D.I., C.I.)	D875	04381
15/16" Drill (For D.I., C.I.)	D938	04382
1-7/16" Hole Saw (For D.I., C.I.)	HS1438	04370
1-3/4" Hole Saw (For D.I., C.I.)	HS1750	04371
1-7/8" Hole Saw (For D.I., C.I.)	HS1875	04372
*** 1/4" Pilot Drill (For D.I., C.I.)	PD25	04373
11/16" Shell Cutter (For PVC)	PL688	04385
7/8" Shell Cutter (For PVC)	PL875	04386
1-7/16" Shell Cutter (For PVC)	PL1438	04387
1-3/4" Shell Cutter (For PVC)	PL1750	04392
Corp Stop Adapters		
** 3/4" AWWA Corp Adapter	DMCA75	08423
** 1" AWWACorp Adapter	DMCA100	08424
*** 1-1/2"AWWA Corp Adapter	DMCA150	08425
*** 2" AWWA Corp Adapter	DMCA75	08426
1-1/2"NPT Corp Adapter	DMCA75	08428
2" NPT Corp Adapter	DMCA75	08429
Miscellaneous		
3/4" NPT to AWWA Converter	DM75CONV	98472
1" NPT to AWWA Converter	DM100CONV	98472
* Ratchet Handle 13/16" Sq.	RWR1316	40383
Power Drive Adapter	TMPDA	08430

* Standard with all machines

** Standard with DM1000 & DM2000 machines

*** Standard with DM2000 machines

(1) Used in DM1000 or DM2000 with D688 drill

(2) Used in DM1000 or DM2000 with D875 and D938 drills

(3) Used in DM1000 or DM2000 with PL688 and PL875 shell cutters

(4) Used in DM1000 or DM2000 with all hole saws and PL1438 and PL1750 shell cutters.

CDTM MACHINE

Conversion Instructions

Note: The CDTM1000 or CDTM2000 is shipped from the factory assembled as a TM1000 with the balance of parts necessary to complete a DM1000 or DM2000 included in the toolbox.

A) To convert from TM1000 to DM1000 or DM2000

- 1) Remove the TM1000 boring bar assembly from the underside of the top cap by releasing the cam handle and sliding the assembly out.
- 2) Unscrew the brass threaded body from the top cap.
- 3) Insert the square end of the drilling machine boring bar assembly into the brass threaded body all the way through.
- 4) Select proper corp and drill adapters for the size of the water service.
- 5) See DM1000/DM2000 operating instructions.

B) To convert from DM1000 or DM2000 to TM1000

- 1) Remove the drilling machine boring bar assembly from the brass threaded body by releasing the cam handle and sliding the assembly out.
- 2) Screw the brass threaded body into the top cap.
- 3) Insert the square end of the TM1000 boring bar assembly into the underside of the top cap all the way through.
- 4) Select proper corp and drill tap for the size of the water service.
- 5) See TM1000 operating instructions.

TM1000 MACHINE

Operating Instructions

Warning:

The maximum operating pressure for this tool is 90 psig (621kPa) When using a power clevis, the maximum operating pressure is 250 psig (1724 kPa)
Do NOT use this tool on natural gas or petroleum piping.

I) Select proper tools necessary to perform tap.

- A) Corporation stop.
- B) Drill tap size to match corporation stop threads.
- C) Proper size saddle.
- D) Proper size corporation inserting tool.
- E) Any other necessary accessories to meet operating requirements.

II) Assemble chamber to the pipe.

- A) Clean area of pipe where tap is to be performed. REED Descaler DS12 or DS36 may be used.
- B) Place saddle gasket on the pipe with hub up.
- C) Place the saddle over the gasket fitting hub into center hole.
- D) Place the disc gasket in the top recess.
- E) Unscrew the top cap (assembled with boring bar).
- F) Place the machine chamber onto the disc gasket recess. Make sure the machine is positioned so the swing valve is on the same side as the operator.
- G) Place chain hooks and swivels into slots on both sides of the chamber.
- H) Connect the chain to one of the chain hooks, bring chain under the pipe and connect on the other side to the nearest link. Hand tighten nuts.

NOTE: Use additional chain extensions and clevis for diameters over 16”.

- I) Position chamber at desired angle. Tighten down chain nuts, evenly, using REED CW12 adjustable wrench, and the gaskets make good contact.

NOTE: Make sure the chain is not twisted and that the machine is clamped securely about the saddle and pipe.

III) Insert tool into Boring bar.

- A) Push knockout pin in boring bar to its holding position. (Toward flat side of bearing sleeve).
- B) Insert shank end of drill tap and align pin with slots in bar end.
- C) Make sure tool is securely seated and tighten the tool retaining screw.
- D) Retract tool end of boring bore all the way into the top cap.
- E) Generously coat tap with REED #98425 tapping compound. (supplied)

IV) Assemble top and bottom halves

NOTE: Before assembly open the swing valve, visually make sure swing valve is NOT seated in the tapping chamber, in closed position.
Make sure the star knob is turned all the way down, and the brass relief valve closed

- A) Screw boring bar top cap hand tight onto the top chamber (1 3/4 turns) .
- B) Push down boring bar slowly until bit touches the pipe.

- C) Adjust feed housing to allow the tool to be fed through drill stage and beginning of tap portion. A good rule of thumb is to stop when the clamp collar is located on the top serrated portion of the boring bar.
- D) Put ratchet wrench on top of boring bar.
- E) Swing and tighten cam handle to front face of the clamp collar.
- F) Make sure the split clamp is securely tighten to the boring bar.

V) Drilling and Tapping

- A) Adjust the ratchet wrench to turn clockwise.
- B) Drill through the pipe by pulling the ratchet wrench clockwise and turning the feed housing clockwise in a smooth and consistent manner. When the boring bar and feed housing turn easily then the drill portion is complete.
- C) If appropriate, open the ball valve to allow flushing of chips while drilling.
- D) After drilling continue feeding drill tap down until resistance is met. This will start the tapping portion.
- E) To start the tap, rotate the ratchet wrench and continuously turn the feed housing.
 - NOTE:** Rotate in a smooth and constant manner. Do NOT force the feed housing, this will cause stripping of the threads.
- F) Once tapping is started, release the cam handle and turn the feed housing down until it bottoms. Continue tapping until start of the 3/8" wide groove in the boring bar is flush with the clamp collar. This may be the depth required for a satisfactory tap. Two smaller grooves in 1/8" graduations may be used to more precisely set the depth.
 - NOTE:** This is the nominal setting. Resharpended drill taps may require two additional turns. Other manufacturer's drill taps may vary. Consult drill tap manufacturer's instructions.
- G) Reed has available a power drive adapter (# 98427) that is adaptable to the Ridgid® #700 or the Collins® power drives. When using this adapter, the operator is able to control the feed rate for drilling. Tapping is performed as stated in part F above.

VI) Tool Removal

- A) Reverse the ratchet detent lever and carefully back the tool out of the tapped hole using a counterclockwise rotation.
 - Caution:** When operating under pressure, be sure to apply downward pressure to stop the piston action of the the boring bar to prevent bodily injury or machine damage.
- B) Once the tap is free of the pipe, retract the boring bar to its uppermost position.
- C) Close the swing valve by pushing down on the handle and turning it 90 degrees counterclockwise.
- D) Open the pressure relief valve on the top chamber.
- E) Unscrew the top cap assembly from the valve chamber.
- F) Loosen the tool retaining screw and strike the end of the knockout pin to release the drill tap.

VII) Attaching Corporation Stop to Boring Bar

Note: It is important to make sure the corp stop to be inserted is the correct size and is fully closed.

- A) Screw the corp stop and corp adapter together. Screw the adapter shank to the corp adapter.
- B) Push knockout pin in boring bar to its holding position. (Toward flat side of bearing sleeve).
- C) Insert tapered end of the adapter shank into the boring bar and align the pin with the slots in the bar end. Tighten the tool retaining screw.
- D) Make sure the boring bar is retracted all the way into the top cap. Apply non-toxic pipe dope to corp inlet threads.
- E) Screw assembly into the valve chamber.

VIII) Inserting the Corp Stop

- A) Attach the ratchet wrench onto the boring bar and set it for clockwise rotation.

- B) Turn the star knob counterclockwise 1 turn to balance the pressure.
- C) Push down on the swing valve handle and turn 90 degrees clockwise.
- D) Push the boring bar down until the corp stop threads touch the pipe.
Note: For pressures greater than 90 psi, the feed housing could be unscrewed and the cam handle tightened to lock the boring bar. The boring bar could then be fed down using the feed housing. A power clevis could also be used.
- E) If not already done, swing the cam handle and tighten it to lock the boring bar to the feed housing.
- F) To start the engagement, rotate the boring bar clockwise while carefully turning the feed housing clockwise. Once the threads are engaged, release the cam handle. Continue rotating until the corporation stop feels solid. Do not attempt to permanently tighten the corporation stop with the machine.

IX) Releasing the Corporation Adapter

- A) Reverse the ratchet to turn counterclockwise.
- B) Remove play from the ratchet wrench with one hand, and strike the wrench handle with the other hand to disengage the corporation adapter from the adapter shank.
- C) Rotate the ratchet wrench counterclockwise until the adapter shank is completely free.
Note: The chip flush valve may be open to release static pressure in the chamber and to determine the quality of the seal in the corporation threads. If there is a constant pressurized flow from the valve, then the boring bar should be carefully pushed down again to repeat step VIII.

X) Machine Removal

- A) Loosen the chain hook nuts and unhook the chain and remove hooks from the machine.
- B) Carefully, remove the machine, saddle, and gaskets and place on a clean surface.
- C) Tighten the corporation stop, using a suitable wrench on the inlet thread side.
- D) Remove the corporation adapter.

TM1000 Maintenance Instructions

Before Using

I) Clean and oil all bearing and wear surfaces and threads.

- A) Inspect and clean tapping bits, and remove any chips or scale which might prevent proper function of the tool.
- B) The boring bar tool end should be inspected to remove any scale or chips which may interfere with the insertion of tapping bit or adapter shank.

After Using

I) Clean the machine and oil the machined surfaces. The tapping compound supplied (#98425) is useful in this application for the tool holding area of the boring bar.

II) If necessary, flush the bottom chamber with a water hose to remove any chips that may have accumulated.

NOTE: Do not hammer frames to remove chips or debris - Handle Carefully! Protect threaded pieces by assembling them with their mating parts. Clean, dry and lubricate all parts. If necessary, the top and bottom chambers can be easily disassembled to clean more thoroughly.

III) Periodically, inspect the boring bar's o-ring seals and replace if worn.

IV) Carefully, place the tool back in the tool box for storage.

DM1000/DM2000 DRILLING MACHINES

Operating Instructions

I) Select proper tools necessary to perform drilling operation.

- A) Service Saddle.
- B) Corporation stop.
- C) Drill size and drill adapter to match corporation stop bore.
- D) Corp adapter with flush valve.
- D) Any other necessary accessories to meet operating requirements.

II) Assemble saddle to the pipe.

- A) Clean area of pipe where tap is to be performed. REED descaler DS12 or DS36 may be used.
- B) Assemble service saddle on the pipe where desired and tighten securely.

III) Insert corporation stop into saddle threads.

- A) Thread sealant may be used.
- B) Tighten corporation stop with an adjustable wrench.
Note: Make sure corporation stop valve is open.

IV) Screw threaded body into the corp adapter.

V) Assemble drill adapter and appropriate drill into boring bar.

A) If you are using the unit for drilling 1-1/2" or 2", the hole saw adapter and hole saws with pilot drills are needed. Screw the hole saw onto the arbor body and line up holes after hand tightening. Assemble the driver into the body and hole saw. Insert the pilot drill into the arbor body. Allow a maximum of 1/4" of the drill tip to protrude from the hole saw. Line up the slot in the drill with the set screw and tighten with the hex key wrench provided. (When using on PVC, a pilot drill is not necessary.) See fig. 1 below.

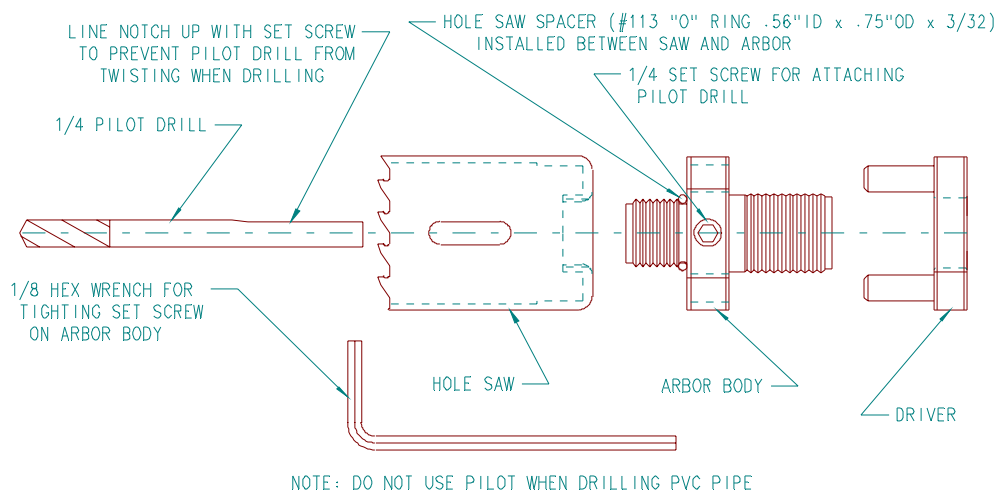

Figure 1.

VI) Screw corp adapter onto corporation stop.

VII) Drilling

- A) Run drill bit down until it touches the pipe.
- B) Swing cam handle and tighten.
- C) Attach ratchet wrench on square drive and turn drill clockwise while turning the feed housing to feed the drill. **Note: Do not attempt to overfeed and force the drill.**
- D) Open the ball valve on the side of the corp adapter to allow the flushing of chips.
- E) Once the drill is completely through the pipe, release the cam handle to allow the boring bar to return to its uppermost position.

Note: Put downward pressure on the boring bar to keep it from traveling too fast upward and potentially damaging the machine.

VIII) Close off the corporation stop using an adjustable wrench.

IX) Disassemble machine from corporation stop.

X) Assemble tubing to corporation stop per tubing and fitting manufacturer's specs.

DM1000/DM2000 Maintenance Instructions

Before Using

I) Clean and oil all bearing and wear surfaces and threads.

- A) Inspect and clean drill bits, and remove any chips or scale which might prevent proper function of the tool.
- B) The boring bar, drill adapters, drills, and corp adapters threaded ends should be inspected to remove any scale or chips which may interfere with thread engagement.

After Using

I) Clean the machine and oil the machined surfaces. The tapping compound supplied (P/N 98425) is useful in this application for the tool holding area of the boring bar.

II) If necessary, flush the corp adapters with a water hose to remove any chips that may have accumulated.

NOTE: Do not hammer parts to remove chips or debris - Handle Carefully!
Protect threaded pieces by assembling them with their mating parts. Clean, dry and lubricate all parts.

III) Periodically, inspect the boring bar's o-ring seals and replace if worn.

IV) Carefully, place the tool back in the tool box for storage.

Reed Drilling Machine - New Applications

Standard DM1000 drill through 3/4" and 1" AWWA corporation stops and saddles. The DM2000 will be for use with 3/4" - 2". If you are inquiring about the need for other drilling applications, the following information is necessary.

Pipe Material	_____				
Pipe Diameter/Thickness or Rating	_____				
Pipe Media (steam, nat. gas etc.)	_____				
Service pressure	_____				
Corporation/Valve Size (See sketch)	A	B	C	D	E
Corporation/Valve Style and Brand	_____				
Other	_____				

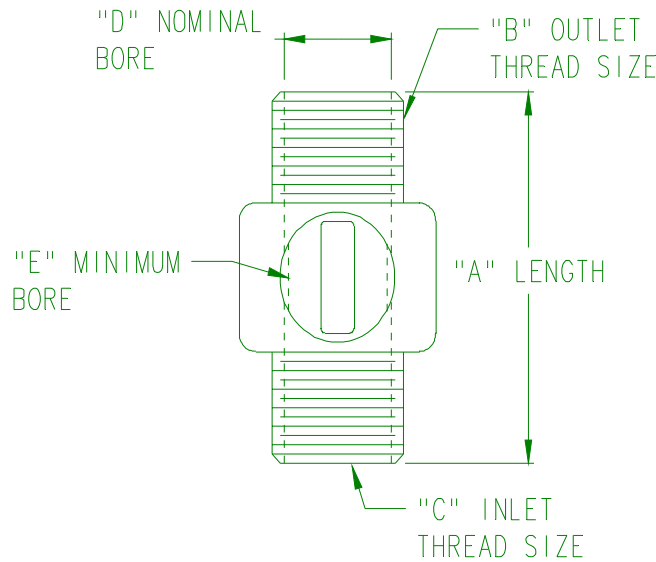

From: Name: _____
 Address: _____

Phone: _____

Fax: _____

Direct inquiries to the Reed Engineering Department

Reed Manufacturing Co.
 P.O. Box 1321
 1425 W 8th St.
 Erie, Pa. 16502
 Ph. (800) 666-3691
 Fax. (800)456-1697