

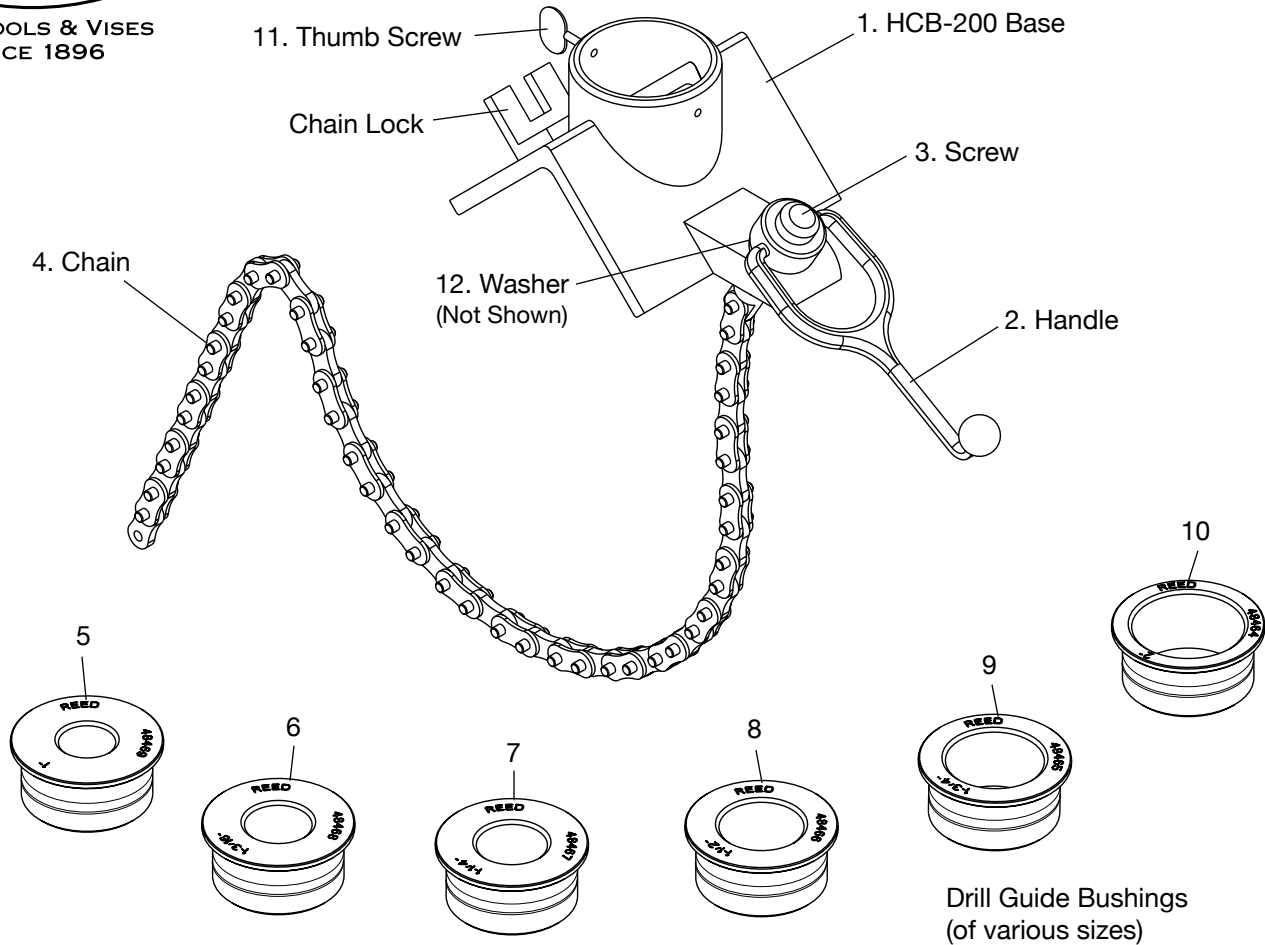

PIPE TOOLS & VISES
SINCE 1896

HCB-200 Hole Master® Operating Instructions



1. Attach the HCB-200 to the pipe by wrapping the chain around the pipe and securing it to the Chain Lock.
2. Use the Handle to tighten the chain in the Chain Lock and around the pipe. Securing the HCB-200.
3. Install the appropriate size Drill Guide Bushing into the HCB-200. Tighten Thumb Screw to hold in place.
4. Install the appropriate hole saw with pilot drill to the drill motor (not included).
5. Insert the hole saw with pilot drill into the Drill Guide Bushing before starting the drill motor.
6. Start the drill motor, set the pilot drill on the pipe and begin the cut by advancing the hole saw through the pipe. Use a slow steady pressure.
7. Once the hole cutting is complete, turn off the drill motor then remove the hole saw and pilot drill back out of the pipe and Drill Guide Bushing.

Parts List

Ref. No.	Description	Item Code	Qty.
1	HCB-200 Base	48471	1
2	Handle	92007	1
3	Screw	94457	1
4	Chain	99013	1
5	1" Drill Guide Bushing	48469	1
6	1-3/16" Drill Guide Bushing	48468	1
7	1-1/4" Drill Guide Bushing	48467	1
8	1-1/2" Drill Guide Bushing	48466	1
9	1-3/4" Drill Guide Bushing	48465	1
10	2" Drill Guide Bushing	48464	1
11	Thumb Screw	99014	1
12	Washer	99024	1