



PIPE TOOLS & VISES
SINCE 1896

Hole Master® Operating Instructions

Catalog No. HCB-475D
Item Code: 08442

Catalog No. HCB-475M
Item Code: 08441

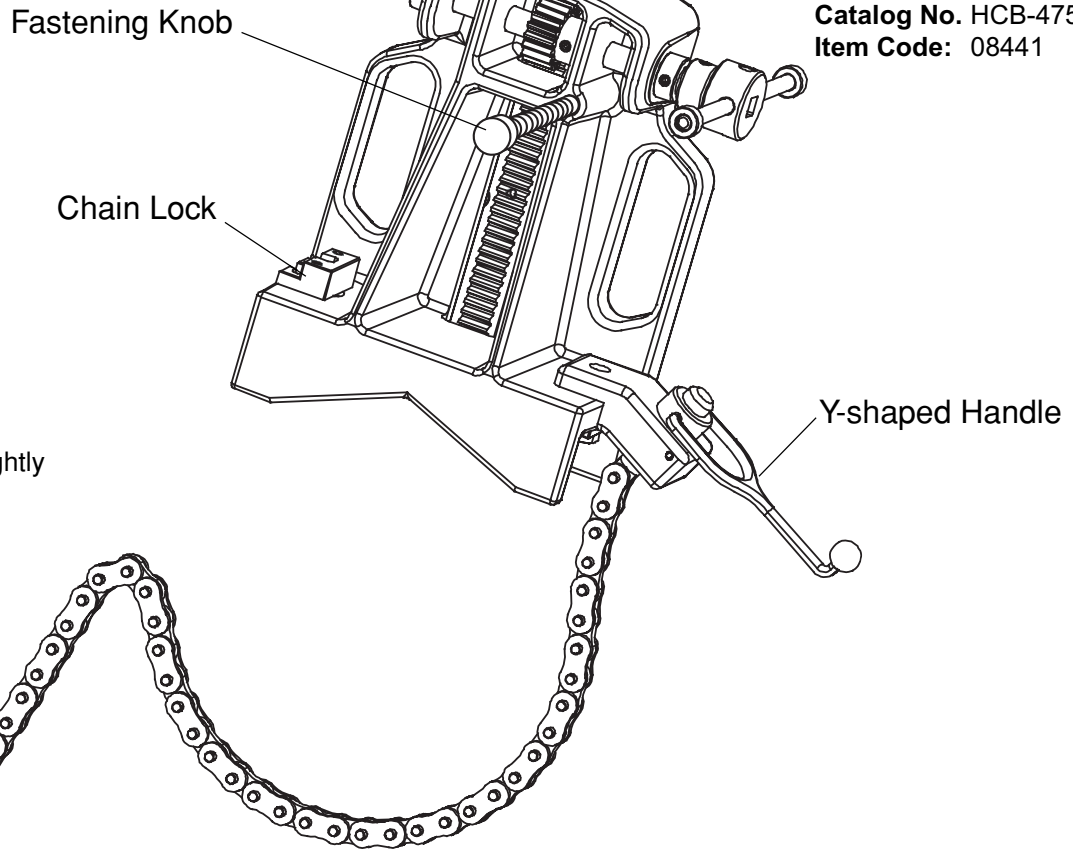

TIP: Backing off the drill slightly can clear the drilling area.

Using the Reed Hole Master® Cutting Tool.

1. Attach the Hole Master® to the pipe by placing the chain around the pipe and secure it into the Chain Lock.
2. Use the "Y-shaped Handle" to tighten chain in the Chain Lock.
3. Secure power drill to drill holder. A 3/8" hex Allen wrench is required to tighten the drill holder fastener. Check to make sure correct drill is used with the designated drill holder.
4. The two "spade handle" fasteners are also required to secure power drill to the drill holder. Small holes are pre-drilled to required depth. (See #2, right column.)
5. Install the Mounting Plate into the Hole Master base. Tighten Mounting Plate with the Fastening Knob.
6. Install hole saw with pilot drill into the power drill. Loosen Fastening Knob.
7. Turn on the drill, set the pilot drill on pipe and begin the cut by advancing the hole saw through the pipe.
8. Upon hole cutting completion, back off the drill and secure it with the Fastening Knob.

9. Remove the Mounting Plate, with drill, from the Hole Master. Safety first!

Mounting Milwaukee® Drill or Dewalt® Drill to the Mounting Plate.

1. Remove spade handle from the drill as required.
2. Attach the drill to the Drill Holder using 98951 Drill Adapter and the screws from the Spade handle. Install drill adapter into drill loosely. Install the proper adapter and screws. Tighten the screws down. Tighten the drill adapter.
Small holes are predrilled to required depth.
 - a. Dewalt Model DW131 1/2" Spade Handle Drill requires 98952 Drill Holder.
 - b. Milwaukee Models: 1660-1 or 1660-6 1/2" Compact Hole Shooter requires 98953 Drill Holder.
3. Attach the Drill Holder to the Mounting Plate using 1/4" - 20 x 3/4" long screws provided.

NOTE: Hole Master® drills up to 4 1/4" holes



PIPE TOOLS & VISES
SINCE 1896

Hole Master®

Replacement Parts

Hole Cutting Base

Item Code: 08441 HCB-475M

Item Code: 08442 HCB-475D

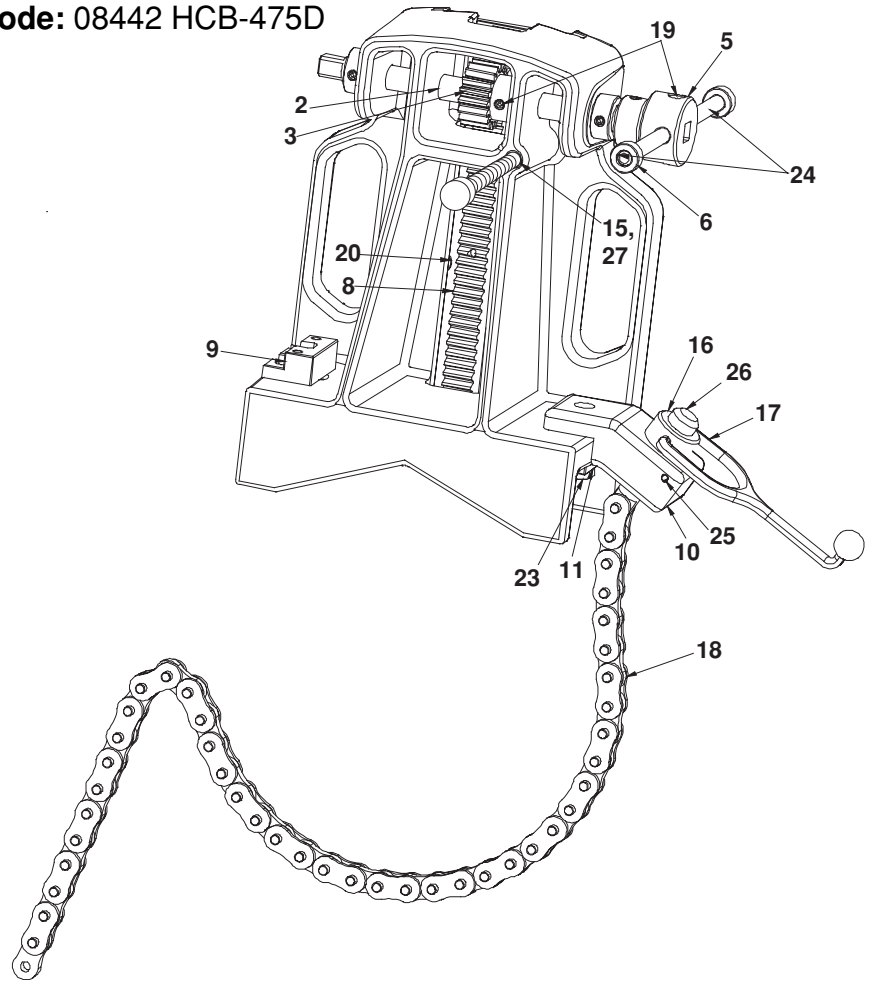
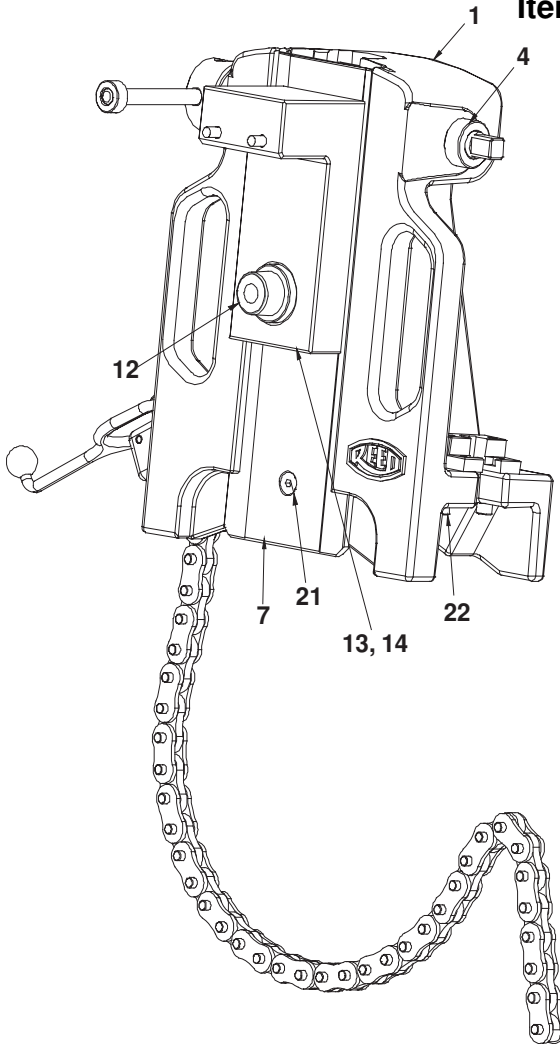

Parts List

Ref. No.	Description	Item Code	Qty.	Ref. No.	Description	Item Code	Qty.
1	Drill Press Housing	98940	1	14	Drill Holder for 08441 only	98953	1
2	Shaft	98941	1	15	Screw with Knob	38440	1
3	Gear	98942	1	16	Nut	99026	1
4	Collar	98943	2	17	Handle	92007	1
5	Handle	98944	1	18	30" Chain	98954	1
6	Handle Arm	98945	1	19	3/8" Set Screw	30113	3
7	Mounting Plate	98946	1	20	5/8" FHCS	38842	4
8	Height Adjuster Rack	98947	1	21	3/4" FHCS	38843	3
9	Chain Lock	98948	1	22	1-1/2" SHCS	37668	2
10	Chain Adjuster Holder	98949	1	23	Hex Bolt	38844	1
11	Clamp	98950	1	24	Collar	38848	1
12	Drill Adapter	98951	1	25	2" Roll Pin	38846	1
13	Drill Holder for 08442 only	98952	1	26	3/4 - 4 Screw	98955	1
				27	Plastic Foot	38441	1

Reed Manufacturing Company
1425 West 8th St.
Erie, PA 16502 USA

QUALITY
& Service
that Last a Lifetime

Phone: 800-666-3691 or 814-452-3691
Fax: 800-456-1697 or 814-455-1697
www.reedmfgco.com

RP-509-78
58440-509