

DM1000/DM2000/DMBASE Necessary Accessories

DESCRIPTION	CATALOG NO.	ITEM CODE
Drill Adapters		
** Drill Adapter 3/4"	DA75	98461
** Drill Adapter 1"	DA100	98462
*** Hole Saw Adapter	DMHSA	08413
Drill Adapter - PVC	DMAPVC	94150
Drills/Hole Saws		
11/16" Drill	D688	04380
7/8" Drill	D875	04381
15/16" Drill	D938	04382
1-7/16" Hole Saw	HS1438	04370
1-3/4" Hole Saw	HS1750	04371
1-7/8" Hole Saw	HS1875	04372
1/4" Pilot Drill	PD25	04373
11/16" Shell Cutter	PL688	04385
7/8" Shell Cutter	PL875	04386
1-7/16" Shell Cutter	PL1438	04387
1-3/4" Shell Cutter	PL1750	04392
Corp Stop Adapters		
** 3/4" AWWA Corp Adapter	DMCA75	08423
** 1" AWWACorp Adapter	DMCA100	08424
*** 1-1/2" AWWA Corp Adapter	DMCA150	08425
*** 2" AWWA Corp Adapter	DMCA75	08426
1-1/2" NPT Corp Adapter	DMCA75	08428
2" NPT Corp Adapter	DMCA75	08429
Miscellaneous		
3/4" NPT to AWWA Converter	DM75CONV	98472
1" NPT to AWWA Converter	DM100CONV	98472
* Ratchet Handle 13/16" Sq.	RWR1316	40383
Power Drive Adapter	TMPDA	08430

- * Standard with all machines
 ** Standard with DM1000 & DM2000 machines
 *** Standard with DM2000 machines



Pipe Tools & Vises
Since 1896

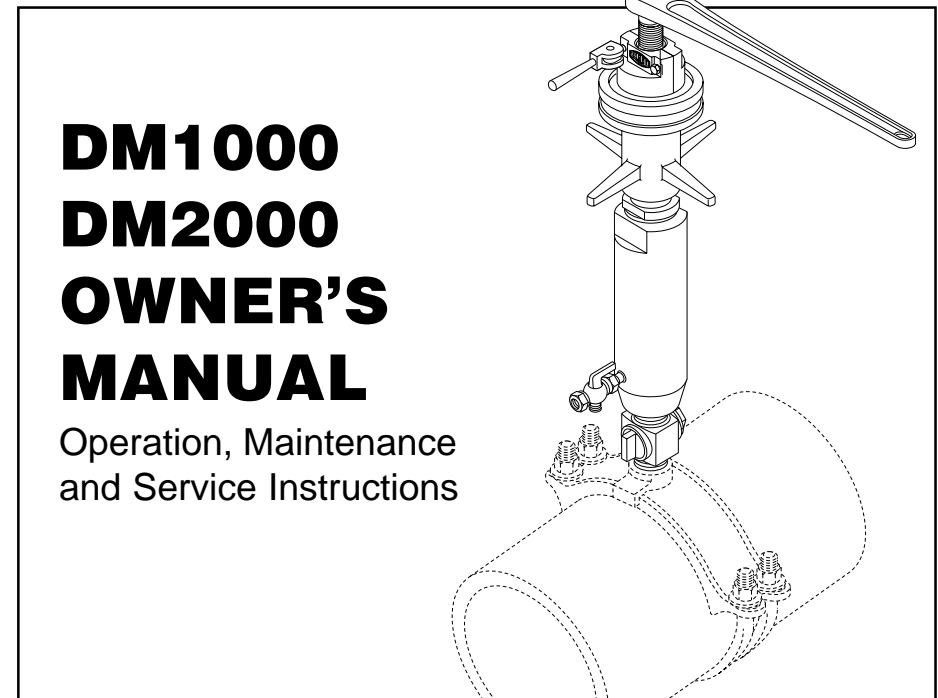

Attention:

Read and fully understand instructions before operating the DM1000 or DM2000 drilling machine. It is essential to properly train and review with operating personnel to prevent possible bodily injury and property damage. It is advantageous to practice drilling a piece of pipe to acquaint personnel with the machine.

Contents:

- Basic Product Information
- Necessary Accessories
- DM1000/DM2000 Operating and Maintenance Instructions
- Parts Illustration & List
- New Drilling Applications Sheet

Basic Product Information

The DM1000 and DM2000 drilling machines drill through the pipe wall via the corporation stop inserted into the service saddle while under pressure. It utilizes Reed D series drills, or hole saws with the aid of a hole saw adapter. The customer will need to purchase necessary drills, hole saws, and drill adapter and shell cutters for PVC.

The DMBASE machine consists of the base unit which allows the customer to purchase individual corp adapters, drill or hole saw adapters, along with necessary drills or hole saws.

With shell cutters and necessary adapters, these units can also be used on C-900 PVC pipe.

Catalog No.	Item Code	Size	Pipe Dia	Shipping Wt
DM1000	08402	3/4" - 1"	N/A	58.2 lbs/26.5 kg
DM2000	08412	3/4" - 2"	N/A	60.9 lbs/27.7 kg
DMBASE	08401	N/A	N/A	35 lbs/15.9 kg

Specifications

- Overall weight of the drilling machine with accessories (43 lbs) is 30% less than Mueller® E-5 and D-5 drilling machines.
- Tool Box over all outside dimensions, DM machines - 23 x 10 1/2 x 11 3/8
- Machine Clearance radius DM1000/DM2000 = 27 1/2"
- **Pressure Rating:** Design pressure rating = 300 psi.
- **Operating Pressure Rating** - 90 psi - ie - Drilling or Tapping into pressurized mains.

WARNING:

Drilling into highly pressurized mains is not recommended; however, is permissible at pressure up to 250 psi if utilizing special precautions and incorporating high pressure attachments such as the Mueller Power Clevis #H-10800®. (See *DM1000/DM2000 Owner's Manual*.)

Do not drill into petroleum or natural gas pipes.

- Flushing/blow by port: 1/2-14 NPT plugged port is provided.
- All machines come complete with tool box, wrenches and Tapping Compound (#98425).
- Manual or power drive operation through 13/16" square shaft. Power drive adapter optional.
- Materials and finish:
 - A. Hard anodized and powder epoxy painted aluminum frames
 - B. Alloy steel boring bar
 - C. Bronze and zinc aluminum parts
 - D. Anodized aluminum corp adapters
 - E. Nitrile "O" rings
 - F. Plated steel parts for corrosion resistance

DM1000/DM2000 DRILLING MACHINES Operating Instructions

- Select proper tools necessary to perform drilling operation.**
 - A. Service saddle
 - B. Corporation stop
 - C. Drill size and drill adapter to match corporation stop bore
 - D. Corp adapter with flush valve
 - E. Any other necessary accessories to meet operating requirements
- Assemble saddle to the pipe.**
 - A. Clean area of pipe where tap is to be performed. REED DS12 (#08000) or DS36 (#08006) may be used.
 - B. Assemble service saddle on the pipe where desired and tighten securely
- Insert corporation stop into saddle threads.**
 - A. Thread sealant may be used
 - B. Tighten corporation stop with an adjustable wrench

Note: Make sure corporation stop valve is open
- Screw threaded body into the corp adapter.**
- Assemble drill adapter and appropriate drill into boring bar.**
 - A. If you are using the unit for drilling 1 1/2" or 2", the hole saw adapter and hole saws with pilot drills are needed. Screw the hole saw onto the arbor body and line up holes after hand tightening. Assemble the driver into the body and hole saw. Insert the pilot drill into the arbor body. Allow a maximum of 1/4" of the drill tip to protrude from the hole saw. Line up the slot in the drill with the set screw and tighten with the hex key wrench provided. (When using on PVC, a pilot drill is not necessary.) See Fig. 1 below.

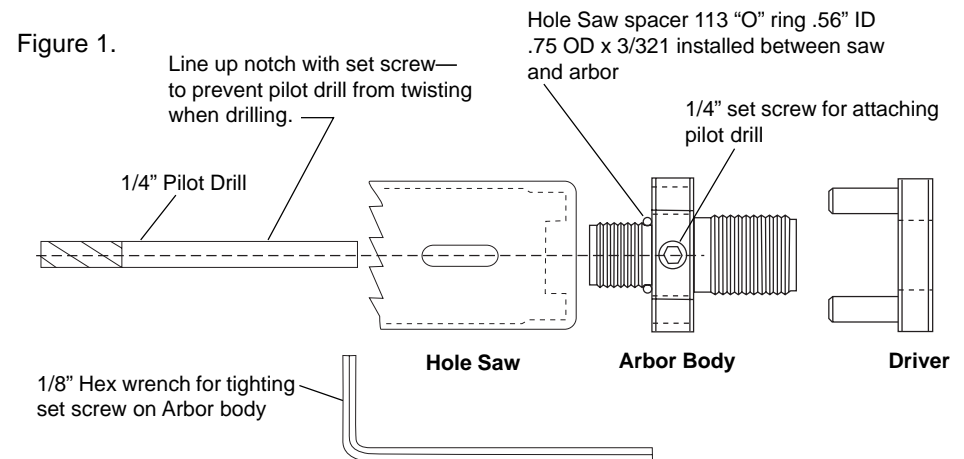

Note: Do not use pilot when drilling PVC pipe

6. Screw corp adapter onto corporation stop.

7. Drilling

- A. Run drill bit down until it touches the pipe.
- B. Swing cam handle and tighten.
- C. Attach ratchet wrench on square drive and turn drill clockwise while turning the feed housing to feed the drill. **NOTE:** Do not attempt to overfeed and force the drill.
- D. Open the ball valve on the side of the corp adapter to allow the flushing of chips.
- E. Once the drill is completely through the pipe, release the cam handle to allow the boring bar to return to its uppermost position.

NOTE: Put downward pressure on the boring bar to keep it from traveling too fast upward and potentially damaging the machine.

8. Close off the corporation stop using an adjustable wrench.

9. Disassemble machine from corporation stop.

10. Assemble tubing to corporation stop per tubing and fitting manufacturer's specs.

DM1000/DM2000 Maintenance Instructions

Before Using

1. Clean and oil all bearing and wear surfaces and threads.

- A. Inspect and clean drill bits, and remove any chips or scale which might prevent proper function of the tool.
- B. The boring bar, drill adapters, drills, and corp adapters' threaded ends should be inspected to remove any scale or chips which may interfere with thread engagement.

After Using

1. Clean the machine and oil the machined surfaces. Tapping Compound (#98425) is useful in this application for the tool holding area of the boring bar.

2. If necessary, flush the corp adapters with a water hose to remove any chips that may have accumulated.

NOTE: Do not hammer parts to remove chips or debris - Handle Carefully!
Protect threaded pieces by assembling them with their mating parts. Clean, dry and lubricate all parts.

3. Periodically inspect the boring bar's o-ring seals and replace if worn.

4. Carefully place the tool back in the tool box for storage.

Reed Drilling Machine - New Applications

Standard DM1000 drill through 3/4" and 1" AWWA corporation stops and saddles. The DM2000 will be for use with 3/4" - 2" If you are inquiring about the need for other drilling applications, the following information is necessary.

Pipe Material _____

Pipe Diameter/Thickness or Rating _____

Pipe Media (steam, nat. gas etc.) _____

Service pressure _____

Corporation/Valve Size (See sketch) A B C D E

Corporation/Valve Style and Brand _____

Other _____

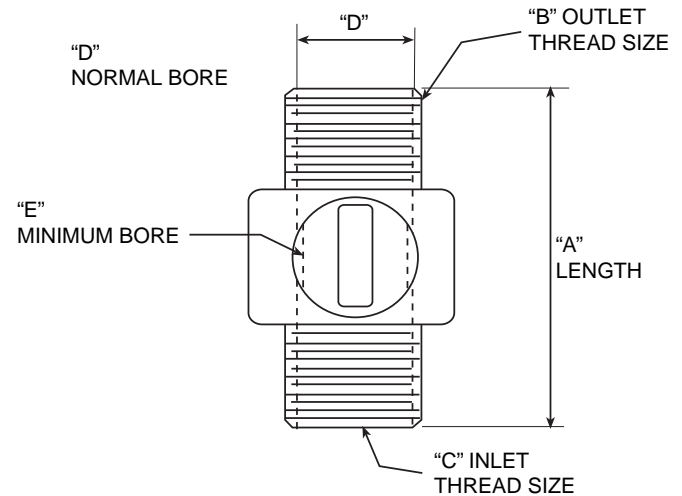

From: _____

Name: _____

Address: _____

Phone: _____

Fax: _____

Direct inquiries to the Product Development Department

Reed Manufacturing Co.
P.O. Box 1321
1425 West 8th St.
Erie, PA. 16502
Phone: 800-666-3691 or 814-452-3691
Fax: 800-456-1697 or 814-455-1697

DM1000/DM2000 Replacement Parts

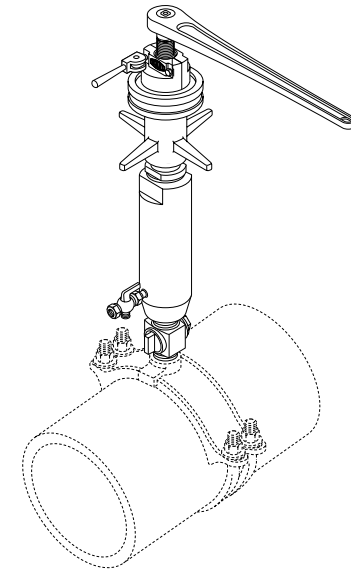
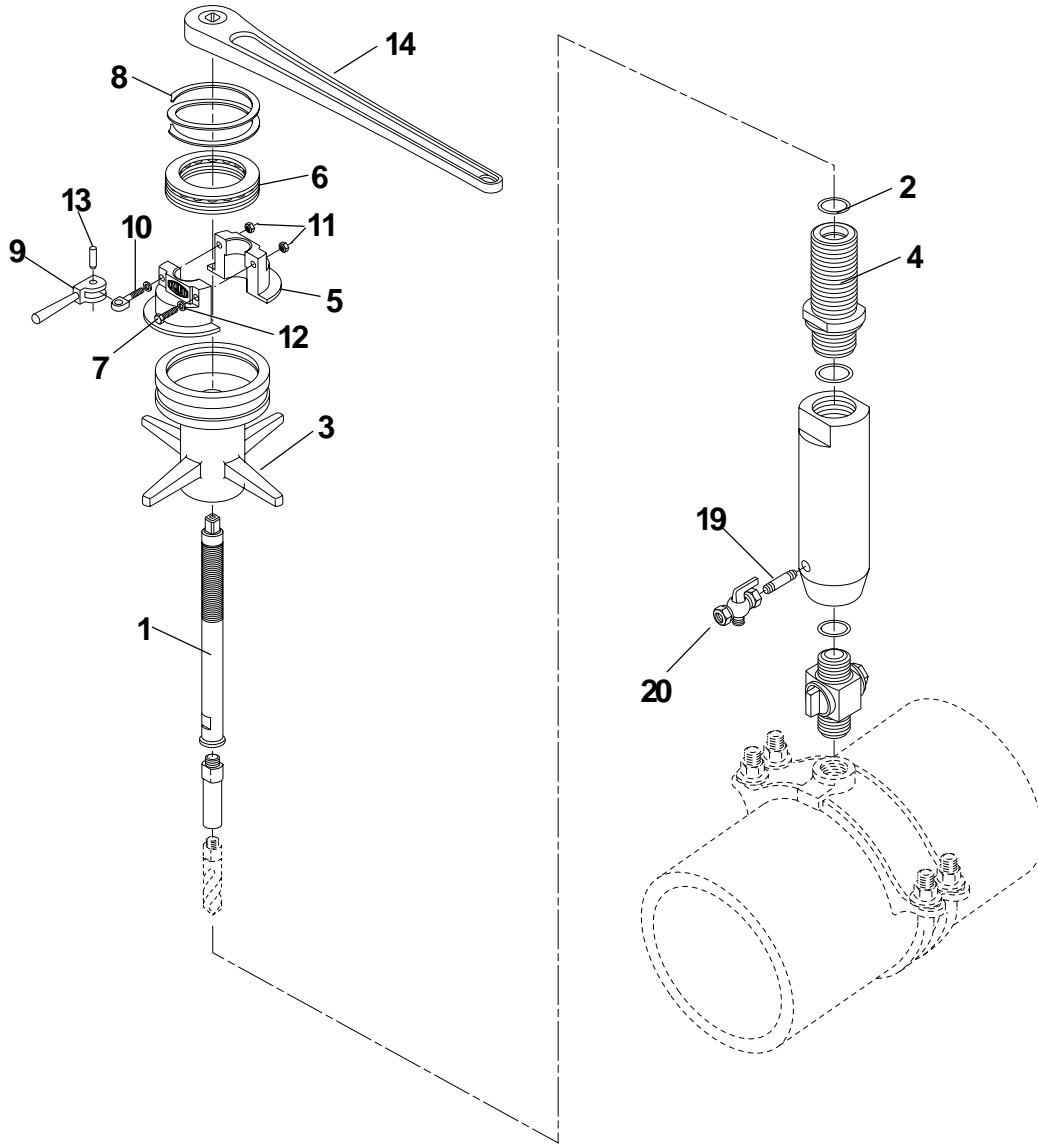

Parts List

Ref. No.	Description	REED Item Code	Cat No.
1	Boring Bar	98460	DMBB
2	O-Ring	40377	TMOTB
3	Feed Housing	98408	TMFH
4	Threaded Body	98402	TMTB
5	Clamp Collar	98413	TMCR
6	Thrust Bearing	40379	TMBRN9
7	Hex Head Cap Screw	30190	TMCST
8	Retaining Ring	40380	TMRR
9	Double Cam	40386	TMFCL-12-CH
10	Swing Bolt	40387	TMFCL-0-SB
11	Lock Nut	30179	TMTNUT
12	Washer	30180	TMTSW
13	Spiral Pin	30161	TMFHSP
14	Ratchet Wrench	40383	RWR1316
15	Carrying Case*	40429	DMTOOLBOX
16	Operating Manual*	50389	XIDM1000
17	Tapping Compound*	98425	TMTC
18	Wrench*	02217	CWB18
19	Brass Nipple	97567	UPFNIP
20	Ball Valve	40396	TMBV
21	Wrench*	02214	CWB10

* Included but not shown