



PIPE TOOLS & VISES
SINCE 1896



Assembly Required.

5401CRT Machine Cart Assembly Instructions

Illustration at right shows how this 5401CRT Machine Cart fits the following machines. Reed Model: 5401TMSO Threading Machine. Ridgid Models: 300 Compact, 535, 535A/585 1224, 1233, 1822.

RIDGID® is a registered trademark of RIDGID, Inc. and is not associated with Reed Manufacturing Company

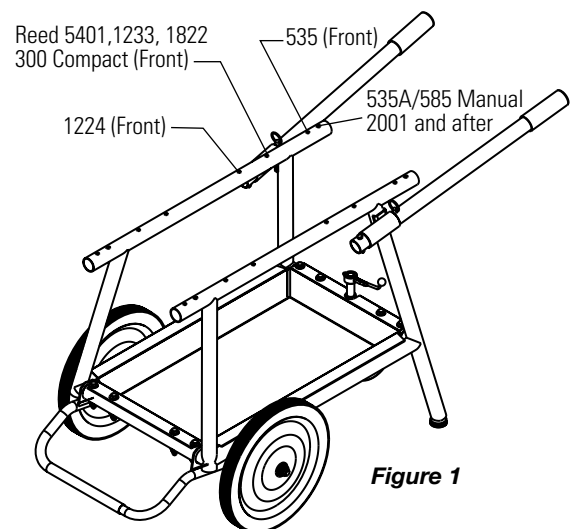

Figure 1

REED MANUFACTURING COMPANY

1425 WEST EIGHTH ST. ERIE, PA 16502 USA PHONE: 800-666-3691 OR 814-452-3691 FAX: 800-456-1697 OR 814-455-1697

www.reedmfgco.com



PIPE TOOLS & VISES
SINCE 1896

5401CRT Machine Cart Assembly Instructions

#06670

1. Assemble left and right side to front and back crosslinks. Ensure the cart stops are put in place at this point. Tool tray needs to be in place before inserting bolts. See Figure 1.
2. Leave all fasteners hand tight until cart is completed.
3. For narrow or wide cart configuration, use bolt holes shown in Figure 3.
4. Install handles (see Figure 2) with bolt and quick release pins.
5. Mount threading machine (see Figure 1) for proper bolt holes for the machine being used.
6. After machine is mounted, tighten all fasteners.

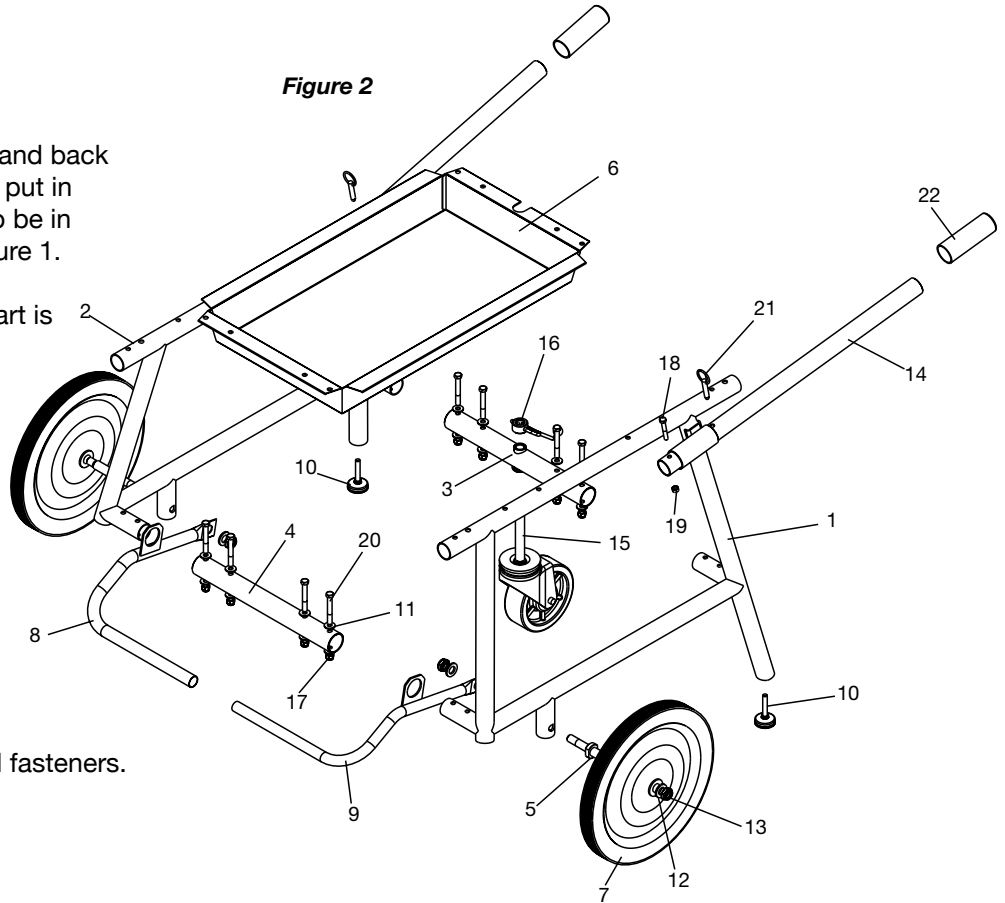
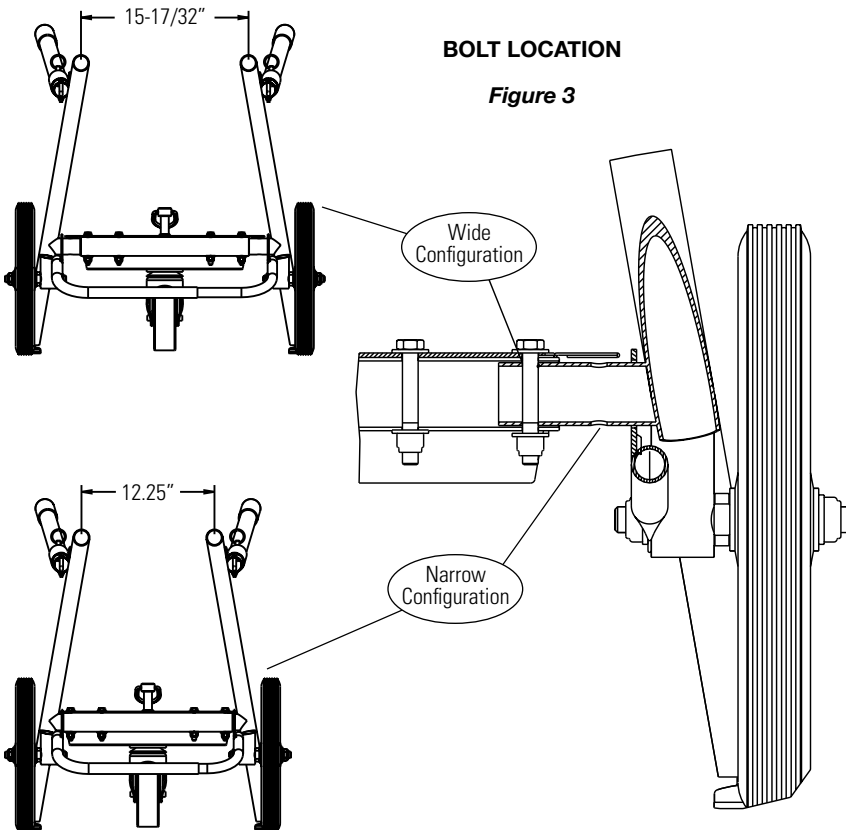

Figure 2



BOLT LOCATION

Figure 3

Parts List

Ref. No.	Description	Item Code	Quantity
1	LEFT SIDE ASSEMBLY	96672	1
2	RIGHT SIDE ASSEMBLY	96671	1
3	BACK CROSSLINK ASSEMBLY	96673	1
4	FRONT CROSSLINK	96670	1
5	WHEEL AXLE	96677	2
6	TOOL TRAY	96680	1
7	WHEEL	46685	2
8	CART STOP, OUTER TUBE ASSEMBLY	96675	1
9	CART STOP, INNER TUBE ASSEMBLY	96676	1
10	LEVELING FOOT	46689	2
11	3/8" WASHER	30011	16
12	M16 WASHER, 17MM ID, 30MM OD, 3MMTHK	30250	4
13	BB 5/8"-11 NYL INSERT HEX JAM NUT	30111	4
14	HANDLE	96679	2
15	CASTER-SCREW ASSEMBLY	96681	1
16	HANDLE-SWIVEL NUT ASSEMBLY	96682	1
17	LOCK NUT 3/8" - 16	23366	8
18	5/16" - 18 X 2" LONG HEX BOLT	30248	2
19	LOCK NUT 5/16" - 18	30245	2
20	BOLT 3/8" - 16 X 2.50"	37321	8
21	QUICK RELEASE PIN	94477	2
22	HANDLE GRIP	34762	2