



PIPE TOOLS & VISES
SINCE 1896

RG1.5 Operating Instructions

Catalog No. RG1.5
Item Code: #08532

Catalog No. RG1.5KIT
Item Code: #08530

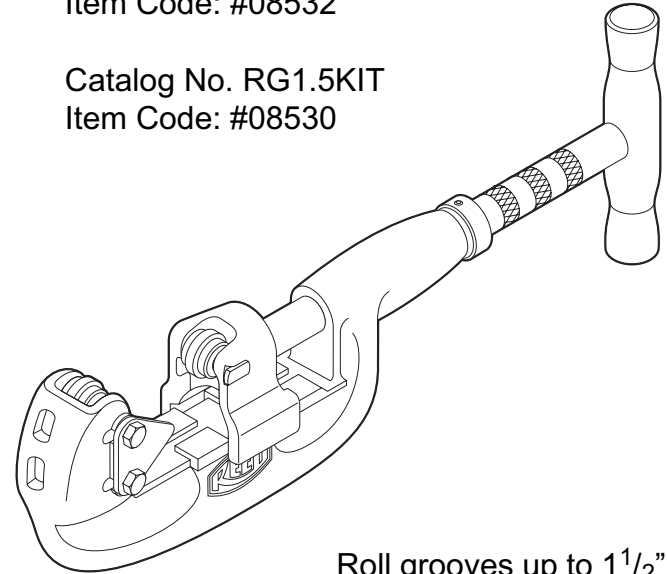

Roll grooves up to 1 $\frac{1}{2}$ ".

Grooving Pipe

1. Position the tool over the pipe with the Alignment Plate touching the end of the pipe. Check the position of the groove wheel on the pipe. Ensure the position meets that specified by the fittings. Flipping the Alignment Plate, adding washers or bending the plate changes the groove position.
2. Rotate the tool around the pipe, applying pressure by turning the Handle Assembly.
3. Advance the Groove Wheel until the Collar contacts the Body. Check the depth of the groove and ensure the depth meets the specifications of the fittings. Adjusting the position of the collar adjusts the depth of groove.
4. Groove the pipe.
5. Back off Handle Assembly and remove tool.

Reed Manufacturing Company
1425 West 8th Street
Erie, PA 16502 USA

BEST SERVICE
QUALITY
PEOPLE
EQUALS LOWEST TOTAL COST

Phone: 800-666-3691 or 814-452-3691
Fax: 800-456-1697 or 814-455-1697
www.reedmfgco.com

Conversion Instructions

Catalog No. RG1.5KIT
Item Code: #08530

Convert Reed Pipe Cutter 2-1 or 2-3 to RG1.5 Roll Groover

1. Remove wheel pin and cutter wheel.
2. Remove Block (and Thrust Cup). Advance the Block by turning the Handle Assembly until the gaps in the Block groove line up with the slots in the Body.
3. Remove Handle Assembly.
4. Place Collar over Handle Assembly and reinstall.
5. Reinstall Block (and Thrust Cup).
6. Remove Rollers and/or Cutter Wheels.
7. Install Groove Wheel in Block.
8. Install Groove Wheel on inner part of Body.
9. Install Groove Wheel, Alignment Plate, Screw and Nut. Ensure step on Alignment Plate faces Cutter Body. Over-tightening the nut and screw can keep the groove wheel from rotating.
10. Set Collar by tightening the tool over pipe to be grooved. Position the Collar about 1/8" from the body and tighten the screw.

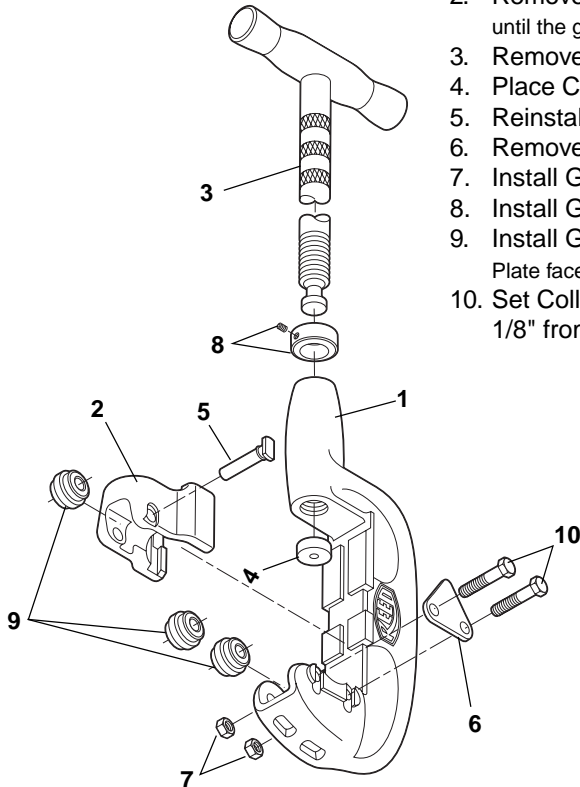

Parts List		RG1.5 Groover 08532		RG1.5KIT 08530		Groover Wheels 08531	
Ref. No.	Description	Item Code	Qty.	Item Code	Qty.	Item Code	Qty.
1	Cutter Body	93673	1				
2	Block	93674	1				
3	Handle Assembly	93675	1				
4	Thrust Cup	93679	1				
5	Wheel Pins or Roller Pins	93310	1				
6	Alignment Plate	98601	1	98601	1		
7	Nylok Nut	30179	2	30179	2		
8	Set Screw/Depth Collar	98602	1	98602	1		
9	Groove Wheels	98600	3	98600	3	98600	3
10	Bolt	98603	1	98603	1		