



# ✓ WHY REED?

## BENEFITS FOR REED CUSTOMERS & COMMUNITY

PIPE TOOLS & VISES  
SINCE 1896



(L-R) Scott Wright (5th generation), Ralph Wright (4th - Chairman Emeritus - deceased), and Mark Wright (5th)



Reed Manufacturing has been producing fine tools for worldwide professional trades since its founding, in 1896, by Carl Reed. The company was purchased in 1902 by Reuben Wright with money he made selling water and hardware during the 1849 California Gold Rush, followed by successful timber businesses in Wisconsin, Michigan, and Western Pennsylvania. The company continues to be operated by his descendants: fifth generation members of the Wright family. Mark Wright and Scott Wright serve as President, Manufacturing & Product Development and President, Sales & Finance, respectively. At Reed in several roles for more than 28 years each, Mark and Scott uphold the family traditions of product innovation, highest quality pipe tools, great customer service, a cutting edge factory and extra value to customers.

Five generations of Wrights have also provided a great place to work and exceptional contributions to the community. Reed Manufacturing is a big supporter of the Erie County United Way (\$3,235 per capita for 2017), the Second Harvest Food Bank along with WQLN Public Television, among others. Additionally, Reed Associates are encouraged to give back to the community through gifts of money and service.

### BEST EVER!

### REED ASSOCIATES



L to R - Debbie Sulecki, Jeff Esmont, Pat Reinke



L to R - Mike Pruzinsky, Bill Stevens, Hector Angel Andrade, Todd Gilpatrick, Tom Fess, Steve Angermeier, Marnie Caldwell



L to R - Minnie Franz, Joyce Carr, Julie Machinski, Tim Donohue, Gene Lachman, Brian Gunderson, Gou-Dong "Jason" Cao, Carrie Applequist, Wan-Xin Werstler, Yousef Hamdan



Hartmut Lutz



Matt Harvey



Chris Reger

The secret of Reed's continuing, increasing success can be attributed to its corporate culture of excellence and the quality of its Associates, who are individually committed to exceptional performance and service. Reed engineers developed many of the most innovative and effective tools in the industry – such as the Quick Release™ Tubing Cutter, the Hinged Cutter™, the Rotary™ Cutter and the Universal Pipe Cutter. Many of these tools have been copied by others, but through continuous improvements and everyday dedication to quality workmanship, Reed products remain the finest in the world.

The goals of each Reed Associate are to ship 95% of orders within three business days, to provide immediate, informed responses to customer inquiries and to produce 100% error-free work. Reed works diligently to cultivate relationships with dependable distributors to reach the end-user market. Selling through traditional, local distributors is the best avenue to strengthen ties with Reed tool users. The strong links in the customer service chain – from product development and manufacturing, through order processing and inquiry fulfillment, to distribution – make Reed a leader in customer satisfaction. Reed identifies the best people to provide the best quality tools which results in the best service available.

**BEST Service** + **BEST Quality** + **BEST People** = **The LOWEST TOTAL COST**

# 1

## CUTTERS & CUTTER WHEELS..... 10

Cutter Wheels.....	7 - 9
Quick Release™ Tubing Cutters (for metal).....	11
Tubing Cutters.....	11
Tubing Cutters for Stainless Steel.....	11
Telescoping Tubing Cutters.....	12
Mini Tubing Cutters.....	12
C Cutters.....	12
Repair Kits.....	13
2" Pipe Cutters.....	13
Deburring Tools (for metal).....	13
Soil Pipe Cutters.....	14
Saw It® Pneumatic Saw.....	15
Power Hack Saw Blades.....	15
Universal Pipe Cutters.....	16 - 17
Filter-Regulator-Lubricator.....	17
Hinged Cutters™.....	18
Hinged Cutters™ with Helper Handle.....	18
<b>NEW</b> Low Clearance Rotary™ Cutters.....	19
Rotary™ Cutters.....	19
Pipe Descalers.....	20
Pipe Reamer (for steel).....	20

## LARGE DIAMETER PIPE TOOLS..... 22 - 23

# 2

## PLASTIC PIPE TOOLS..... 24

<b>NEW</b> Quick Release™ Tubing Cutters for Plastic.....	25
Scissor Shears.....	25
<b>NEW</b> Ratchet Shears.....	26
Plastic Pipe Saws.....	26
Internal Pipe Cutters.....	27
Clean Ream Extreme™.....	27
<b>NEW</b> Solutions Kits.....	28
PE Pipe Peelers.....	28
Flare Tools for PE Water Service Lines.....	28
DEB1 Series Deburring Tools for Plastic Pipe.....	29
DEB4 Deburring Tool.....	29
Cone Deburring Tool.....	29
PEX Crimpers.....	30
Pipe Bevelers (for PVC).....	30
Chamfer Tools Drill-Powered (for PVC/CPVC/ABS).....	30
Universal Pipe Cutters for PE.....	31
PLAS In-Line Rotary™ Cutters (for PE/PVC).....	32
PLAS Hand-Over-Hand Rotary™ Cutters (for PE/PVC).....	32
Guillotine Pipe Cutters (for PE).....	33
<b>NEW</b> PE Squeeze-Off Tools.....	34 - 35
Grounding Accessory.....	35
Static Discharge Alarm.....	35
Plastic Pipe Joiners (for PVC).....	36

# 3

## WATER SERVICES TOOLS & MACHINES..... 37

<b>NEW</b> Feed Tap™ Drilling Machines.....	38
Direct Tapping Machine.....	39
Drill Taps.....	39
Drilling Machines.....	40 - 41
Combination Drilling/Tapping Machines.....	42
PVC/PE Drilling Machines.....	42 - 43
Power Units for Tapping/Drilling.....	43
PE Water Service Shut-Off Tool.....	44
Standing Shut-Off Tool.....	44
Copper Shut-Off Tools.....	44
Flare Tools.....	45
Rerounding Tools.....	45
Brass Hammer.....	45
Round It® Straightener/Rerounders.....	45
Fiberglass Probe Rod.....	46
Meter Pit Pump.....	46
Manhole Hooks.....	46
Drill-Powered Hydrostatic Test Pump.....	47
Electric Hydrostatic Test Pumps.....	47
Hydrostatic Test Pumps.....	47
<b>NEW</b> Valve & Curb Keys.....	48
Ratcheting Valve Keys.....	48
<b>NEW</b> Valve Operators.....	49
Meter Box & Curb Box Lid Keys.....	49

# 4

## GROOVERS, POWER DRIVES, THREADERS & DIES..... 50

Combo Roll Groover.....	51
Portable Roll Groovers.....	51
5301PD Power Drives.....	52
Ground Fault Interrupter.....	52
5401TMSO Threading Machines.....	53
Machine Cart.....	53
700PD Power Drives.....	54
700APD Pneumatic Power Drives.....	54
601PD Power Drives.....	55
Oilers.....	56
Threadguard Cutting Oil.....	56
R12+ Segmental Dies.....	57
R12+ Dropheads.....	57
R12+ Threader Sets.....	57
Universal Dies.....	58
Universal Die Head.....	58
Enclosed Ratchet Threader Sets.....	59
Enclosed Dropheads.....	59
Adjustable Guide Threader Sets.....	60
Block Dies.....	60

<b>5</b>	<b>VICES</b>	61
	<b>NEW</b> Tripod Vises	62 - 63
	Pipe Jacks	63
	Chain Vises	64
	Field Pipe Vise	64
	Yoke Pipe Vises	64
	Utility Workshop Vises	65
	<b>NEW</b> Mid-Line Vises	65
	Combination Bench & Pipe Vise	65
	Brass Vise Jaw Caps	66
	Pipe Welding Vise	66

<b>6</b>	<b>WRENCHES</b>	68
	Pipe Wrenches	69
	60" Pipe Wrench Parts	69
	Aluminum Pipe Wrenches	69
	Chain Tongs	70
	Chain Wrenches	70
	<b>NEW</b> Strap Wrenches	70
	Adjustable Wrenches	71
	Comfort Grip - Adjustable Wrenches	71
	Torque Wrenches for Cast Iron Soil Pipe	71
	Thru-Bolt™ Ratchet Wrenches & Sockets (Standard & Metric)	72
	Thru-Bolt™ Larger Ratchet Wrench & Sockets	73
	Square Drive Ratchet Wrenches	73

<b>NEW</b> Extended Sockets	73
Thru-Bolt™ 4-in-1 Ratchet Wrench	74
Thru-Bolt™ Dual Socket Ratchet Wrenches	74
Thru-Bolt™ Dual Socket Adjustable Ratchet Wrench	75
Basin Wrench	75
One Hand Meter Wrenches	75
Comfort Grip - One Hand Meter Wrench	75
Operator's Wrench	76
Valve Packing Wrenches	76
Valve Wheel Wrenches	76
Smooth Jaw Wrenches	77
Hydrant Wrenches	77
Ratcheting Hydrant Wrench	77

<b>7</b>	<b>GENERAL PIPE WORKING TOOLS</b>	78
	Mechanical Hot Tapping Machines	79
	Tubing Benders	79
	Stud Punch	80
	Multi-Purpose Pipe Joiner	81
	Torpedo Level	81
	Hack Saw & Blades	81
	Water Pump Pliers	82
	Positive Grip Pliers	82
	Threaded Rod Cutters	82

# REED

## MISSION STATEMENT

*Reed will develop a growing market position in the pipe tool industry by providing the most innovative and the highest quality tools, the best customer service, the lowest total cost and the greatest value to distributors and tool users.*



*Reed seeks to utilize very effective personnel, the most modern, cost-effective equipment, and total quality management concepts in order to achieve challenging objectives. Reed also seeks to provide a great place to work, to be environmentally responsible and to be a good corporate citizen.*

[www.reedmfgco.com](http://www.reedmfgco.com)





# SPECIAL FEATURES

PIPE TOOLS & VISES  
SINCE 1896

Throughout the catalog, various symbols are used to help the reader identify key points:



**Reed Exclusive Tool** – The tool is unique, available only from Reed, offers operational cost savings or safety features, and at least one advantage to buying Reed.



**Reed Exclusive Features** – The tool has special features available only from Reed. These meaningful features are advantages to buying Reed.



**Reed Exclusive Sizes** – The tool is available in certain capacities only from Reed. These unique capacities are advantages to buying Reed.



**Reed Best Ever** – The tool has been improved over all previous versions. These continuous improvements are advantages to buying Reed.



**Reed Online Video Training** – Numerous tools offer training videos through the Reed website or YouTube.



**Reed Metric Sizes** – The tool has metric-only sizing. However, Reed offers a wide variety of other tools to fit metric pipe since most tools suit a range of sizes.



Next to many of the tools in this catalog, there is a brief statement headed by the term: "**WHY REED?**" This statement explains why that particular Reed tool is superior to any other on the market, and can be used with confidence to compare Reed products with the competition.



**New Tools** are indicated by  symbol, while models added to the Reed line are highlighted in charts in red ink. To Reed, "**NEW**" means the tool was introduced within the last 12 months.



**Reed Extra Value** – The tool offers extra cost savings over the previous Reed version – or the competitors'.



**Truck Freight Required** – These tools require truck freight due to size or weight.

## REED - REGISTERED & TRADEMARKED

**Clean Cut®**

**Clean Ream Extreme™**

**Clean Ream Plus™**

**Cutter Wheel Headquarters™**

**Feed Tap™**

**Hinged Cutter™**

**Quality First®**

**Quick Release™ Cutter**

**Rotary™ Cutter**

**Round It®**

**Saw It®**

**Thru-Bolt™**

## HOW TO FIND REED DISTRIBUTORS

**BUY NOW »**

LOCAL OR ONLINE

To find the nearest Reed distributor, visit WHERE TO BUY on [www.reedmfgco.com](http://www.reedmfgco.com).

There is a section for FIND A DISTRIBUTOR which uses a zip code/postal code search to identify nearby stocking distributors. There is also SHOP ONLINE DISTRIBUTORS which links to vetted, stocking Reed distributors that also run online retailer websites.

Alternatively, contact Reed Sales or a Reed Regional Manager or Manufacturer's Representative to find a distributor.

# REPLACEMENT WHEELS

FOR EVERY PIPE & PIPE CUTTER



**BEST EVER!**

## ✓ **WHY REED? CUTTER WHEELS ARE BETTER...**

All Reed cutter wheels are made from high shock-resistant tool steel, while competitive wheels are made from carbon steel or still lower quality tool steel. By using this higher quality raw material, Reed cutter wheels can be made thinner and can therefore cut pipe more easily and leave less burr. Also, because of their higher quality, certified material, only Reed wheels can be heat-treated for the perfect balance between hardness and toughness to make the wheels resist breakage and last longer.

Reed pioneered the development of wheels for plastic pipe and today has the widest variety and highest quality wheels for various types and wall thicknesses of plastic pipe and tubing.

Reed offers the largest cutter wheel line for all types of pipe, tubing and conduit. Reed wheels are the best value for use in Reed cutters, or in the cutters of any other manufacturer.

**CUTTER WHEEL INTERCHANGEABILITY CHARTS P. 7-9**

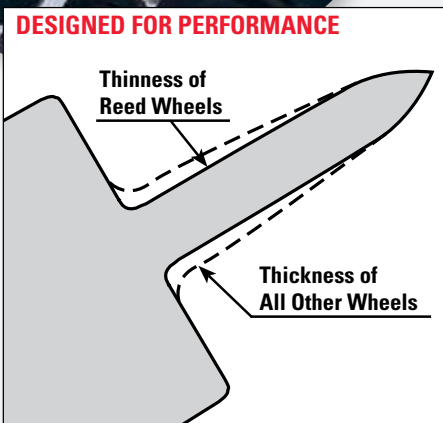

**BE ON THE CUTTING EDGE WITH REED!**



Back



Front

The most popular types of genuine Reed cutter wheels (P. 7) are also sold in convenient, two-pack display bags for quick and easy showroom purchases.

[www.reedmfgco.com](http://www.reedmfgco.com)



PIPE TOOLS & VISES  
SINCE 1896

## Reed 2-Pack Replacement Cutter Wheels

Item Code	Reed Catalog No.	Std. Pack	Reed Cutter	Blade Exposure**		Application
				inches	mm	
<b>FOR TUBING CUTTERS - METAL, 2-PACK</b>						
63375	2PK-SLRCW	1	TC50SL; TC75SL; TC1SL; TC50SLR; TC75SLR; TC1SLR	0.116	2.9	Copper (K, L & M); CTS CPVC
63612	2PK-2RBS	1	2-1; 2-1Q; 2-4WG; 2-3; 2-3Q; 2-4; 5401TMSO	0.300	7.6	Steel; Stainless Steel
63613	2PK-2RBHD	1	2-1; 2-1Q; 2-4WG; 2-3; 2-3Q; 2-4; 5401TMSO	0.296	7.5	HD for Steel; Stainless Steel
63655	2PK-OSS	1	TC1Q; TC1.6Q; TC2Q; T10; T15; T20	0.160	4.1	Stainless Steel
63659	2PK-OCSST-2	1	TC1.6Q; TC1.6RGT; TC2Q; TC2QRGT	0.281	7.1	CSST
63660	2PK-O	1	TC1Q; TC1.6Q; TC2Q; T10; T15; T20; RT15T1; RT15T2; RT15T3; RTC1.1; RTC1.4	0.180	4.6	Copper; Aluminum; Brass; Steel
63661	2PK-32633	1	MC1	0.127	3.2	Copper; Aluminum; Brass; Steel
63662	2PK-75015	1	TC11; TC17	0.125	3.2	Copper; Aluminum; Brass; Steel
63663	2PK-75046	1	TC11; TC17	0.125	3.2	Stainless Steel
63665	2PK-30-40	1	TC3Q; TC4Q; TC5Q; TC6Q; TC8Q	0.250	6.4	Copper; Aluminum; Brass; Steel
63666	2PK-345T	1	MC2; MC2GRIP	0.146	3.7	Copper; Aluminum; Brass
63670	2PK-R2558	1	TC3Q; TC4Q; TC5Q; TC6Q; TC8Q	0.188	4.8	Muffler Systems Tubing
63671	2PK-30-40SS	1	TC3Q; TC4Q; TC5Q; TC6Q; TC8Q	0.160	4.1	Stainless Steel
63690	2PK-73505	1	TC14; TC166; MC3	0.170	4.3	Copper; Aluminum; Brass; Steel
63691	2PK-73515	1	TC14; TC166	0.170	4.3	Stainless Steel Only
<b>FOR TUBING CUTTERS - PLASTIC, 2-PACK</b>						
64180	2PK-OP2	1	TC1Q; TC1.6Q; TC2Q; T10; T15; T20	0.275	7.0	ABS; PE; PEX; PP; PEX/AL/PEX
64184	2PK-1-2PVC	1	TC1Q; TC1.6Q; TC2Q; T10; T15; T20	0.280	7.1	PVC; CPVC; PVDS; ABS
64190	2PK-30-40P	1	TC3Q; TC4Q; TC5Q; TC6Q	0.343	8.7	ABS; PE; PP
64194	2PK-3-6PVC	1	TC3Q; TC4Q; TC5Q; TC6Q	0.377	9.6	3"-6" PVC; 4" Heavy Wall; CPVC

## Reed Replacement Cutter Wheels

Item Code	Reed Catalog No.	Std.* Pack	Reed Cutter	Blade Exposure**		Application
				inches	mm	
<b>FOR TUBING CUTTERS - METAL</b>						
03375	SLRCW	12	TC50SL; TC75SL; TC1SL; TC50SLR; TC75SLR; TC1SLR	0.116	2.9	Copper (K, L & M); CTS CPVC
03655	OSS	12	TC1Q; TC1.6Q; TC2Q; T10; T15; T20	0.160	4.1	Stainless Steel
03657	3T23	4	T23	0.125	3.2	Copper; Aluminum; Brass; Steel
03659	OCSST-2	12	TC1.6Q; TC1.6RGT; TC2Q; TC2QRGT	0.281	7.1	CSST
03660	0	12	TC1Q; TC1.6Q; TC2Q; T10; T15; T20; RT15T1; RT15T2; RT15T3; RTC1.1; RTC1.4	0.180	4.6	Copper; Aluminum; Brass; Steel
03661	32633	12	MC1	0.127	3.2	Copper; Aluminum; Brass; Steel
03662	75015	12	TC11; TC17	0.125	3.2	Copper; Aluminum; Brass; Steel
03663	75046	12	TC11; TC17	0.125	3.2	Stainless Steel
03665	30-40	12	TC3Q; TC4Q; TC5Q; TC6Q; TC8Q	0.250	6.4	Copper; Aluminum; Brass; Steel
03666	345T	12	MC2; MC2GRIP	0.146	3.7	Copper; Aluminum; Brass
03668	R4546	6	MC2; MC2GRIP	0.161	4.1	Steel; Stainless Steel
03670	R2558	12	TC3Q; TC4Q; TC5Q; TC6Q; TC8Q	0.188	4.8	Muffler Systems Tubing
03671	30-40SS	12	TC3Q; TC4Q; TC5Q; TC6Q; TC8Q	0.250	6.4	Stainless Steel
03690	73505	12	TC14; TC166; MC3	0.170	4.3	Copper; Aluminum; Brass; Steel
03691	73515	12	TC14; TC166	0.170	4.3	Stainless Steel Only
<b>FOR TUBING CUTTERS - PLASTIC</b>						
04159	TC56QPP-R	6	TC5Q; TC6Q; TC8Q	0.744	18.9	PP-R including Aquatherm®
04180	OP2	12	TC1Q; TC1.6Q; TC2Q; T10; T15; T20	0.275	7.0	ABS; PE; PEX; PP; PEX/AL/PEX
04184	1-2PVC	12	TC1Q; TC1.6Q; TC2Q; T10; T15; T20	0.280	7.1	ABS; PVC; CPVC; PVDF
04190	30-40P	12	TC3Q; TC4Q; TC5Q; TC6Q	0.343	8.7	ABS; PE; PP
04192	680PVC	4	TC6Q; TC8Q	0.575	14.6	PVC-Standard & Heavy Wall; CPVC
04194	3-6PVC	12	TC3Q; TC4Q; TC5Q; TC6Q	0.377	9.6	ABS; 3"-6" PVC; 4" Heavy Wall; CPVC
04198	6QP	4	TC4Q; TC5Q; TC6Q; TC8Q	0.550	14.0	Thick Wall PE
04199	80P	4	TC6Q; TC8Q	0.750	19.1	ABS; PE; PP
<b>FOR PIPE CUTTERS</b>						
03612	2RBS	12	2-1; 2-4WG; 2-3; 2-4; 5301PD; 5401TMSO	0.300	7.6	Steel; Stainless Steel
03613	2RBHD	12	2-1; 2-4WG; 2-3; 2-4; 5301PD; 5401TMSO	0.296	7.5	HD for Steel; Stainless Steel
03624	2RBCL	4	2-1; 2-4WG; 2-3; 2-4	0.172	4.4	Cast Iron
03616	3RG	4	4-1; 4-3; 4-4; 4-4WG	0.172	4.4	Steel; Stainless Steel
03617	3RGCI	4	4-1; 4-3; 4-4; 4-4WG	0.172	4.4	Cast Iron; Ductile Iron
03532	R1032/S	6	5301PD; 5401TMSO	0.450	11.4	Steel; Stainless Steel; Schd 80

\* Cutter wheels sold to distributors in standard package quantities only.

\*\* Blade Exposure determines wall thickness capacity of cutter wheel.



## Reed Replacement Cutter Wheels

Item Code	Reed Catalog No.	Std.* Pack	Reed Cutter	Blade Exposure**		Application
				inches	mm	
<b>FOR HINGED CUTTERS</b>						
03502	HS21/2	4	H21/2	0.312	7.9	Steel; Stainless Steel
03504	HS4	4	H4; LCRC4	0.316	8.1	Steel; Stainless Steel
03505	HS14	4	H4	0.275	7.0	Steel; Stainless Steel; Cast Iron; Ductile Iron
03506	HS6	4	H6	0.382	9.9	Steel; Stainless Steel; Copper
03507	HS16-8	4	H6; H8	0.350	8.9	Steel; Stainless Steel; Cast Iron; Ductile Iron
03508	HS8-12	4	H8; H12	0.450	11.4	Steel; Stainless Steel
03510	HX21/2	4	H21/2	0.383	9.7	Steel; Stainless Steel; Schd 80
03512	HX4	4	H4; LCRC4	0.383	9.7	Steel; Stainless Steel; Schd 80
03514	HX6	4	H6	0.476	12.1	Steel; Stainless Steel; Schd 80
03516	HX8	4	H8; H12	0.567	14.4	Steel; Stainless Steel; Schd 80
03518	HXX8	4	H8; H12	0.682	17.3	Steel; Stainless Steel; Schd 100
03522	HI4	4	H4; LCRC4	0.258	6.6	Cast Iron; Ductile Iron
03524	HI6	4	H6; H8; H12	0.410	10.4	Cast Iron; Ductile Iron
03525	H6PSE5	4	H6; H8; H12	0.400	10.2	Steel; Cast Iron; Ductile Iron
03624	2RBCI	4	H21/2	0.172	4.4	Cast Iron; Ductile Iron
<b>FOR ROTARY™ CUTTERS</b>						
03530	RCS8-36	4	LCRC8; LCRC12; LCRC16; RC20; RC24; RC30; RC36; RC42S	0.635	16.1	Steel; Stainless Steel
03535	RC18-30	4	LCRC8; LCRC12; LCRC16; RC20; RC24; RC30; RC36	0.500	12.7	Cast Iron; Ductile Iron (manual)
03550	RCX	4	LCRC8; LCRC12; LCRC16; RC20; RC24; RC30; RC36; RC42S	0.800	20.3	Heavy Wall Steel; Stainless Steel

**REQUIRES: ONE SET (8) OF RC8-30XR ROLLERS (93222) WHEN USING RCX WHEELS**

## Reed Replacement Cutter Wheels, by Manufacturer

Manufacturer Cutter No.	Manufacturer Wheel	Reed Cat. No.	Item Code	Std. Pack*	Blade Exposure** inches	mm	Application
<b>RIDGID®</b>							
50	M-50	R2558	03670	12	0.188	4.8	Muffler Systems Tubing
10; 15; 20	E-1240	OSS	03655	12	0.160	4.1	Stainless Steel
10; 15; 20	E-1240	O	03660	12	0.180	4.6	Steel
10; 15; 20	F-158	O	03660	12	0.180	4.6	Copper; Aluminum
101; 103; 104; 105; 118; 150; 150L; 131; 132; 151; 152; 153; 205	E-3469	345T	03666	12	0.146	3.7	Copper; Aluminum; Brass
105; 150; 150L; 131; 132; 151; 152; 153; 205	E-4546	R4546	03668	6	0.161	4.1	Steel; Stainless Steel
131P; 132P; 151P; 152P; 153P; 205P	E-5272	R5272	04186	6	0.295	7.5	PVC; ABS-Standard Wall
134P; 136P; 154P; 156P	E-702	680PVC	04192	4	0.575	14.6	PVC- Standard & Heavy Wall; CPVC
134P; 136P; 154P; 156P	E-2157	60P	04198	4	0.550	14.0	Thick Wall PE
136P; 156P	E-2880	80P	04199	4	0.750	19.1	ABS; PE; PP
1A; 2A; 42A; 202; 300; 360; 820; 364; 732; 300; 535	E-1032S	R1032/S	03532	6	0.450	11.4	Steel; Stainless Steel; Schd 80
1A; 2A; 42A; 202; 360; 820; 364; 732	F-514	2RBS	03612	12	0.300	7.6	Steel; Stainless Steel
1A; 2A; 42A; 202; 360; 820; 364; 732	F-3	2RBHD	03613	12	0.296	7.5	HD for Steel; Stainless Steel
1A; 2A; 42A; 202; 360; 820; 364; 733	F-3S	2RBHD	03613	12	0.296	7.5	HD for Steel; Stainless Steel
1A; 2A; 42A; 206; 360; 820; 364; 732	F-119	2RBCI	03624	4	0.172	4.4	Cast Iron
30; 40; 106; 108; 109; 133; 134; 136; 154; 156	E-2191	30-40	03665	12	0.250	6.4	Copper; Aluminum; Brass; Steel
30; 40; 106; 108; 109; 133; 134; 136; 154; 156	E-2558	30-40	03665	12	0.250	6.4	Copper; Aluminum; Brass; Steel
30; 40; 106; 108; 109; 133; 134; 154; 136; 156	E-2558	R2558	03670	12	0.188	4.8	Muffler Systems Tubing
30P; 40P; 106; 108; 109P; 133P; 134P; 136P; 154P; 156P	E-5299	3-6PVC	04194	12	0.377	9.6	3"-6" PVC; 4" Heavy Wall
30P; 40P; 106; 108; 109P; 133P; 134P; 136P; 154P; 156P	E-5299	30-40P	04190	12	0.343	8.7	ABS; PE; PP
30P; 40P; 133P; 134P; 136P; 154P; 156P	E-2156	30-40P	04190	12	0.343	8.7	ABS; PE; PP
3S; 4S; 44S; 466S; 466C; 466HWS; 468C; 468S; 468HWS; 472C; 472S; 472HWS; 764; 1224	F-229	3RG	03616	4	0.399	10.1	Steel; Stainless Steel
3S; 4S; 44S; 466S; 466C; 466HWS; 468C; 468S; 468HWS; 472C; 472S; 472HWS; 764	F-229S	3RG	03616	4	0.399	10.1	Steel; Stainless Steel
3S; 4S; 44S; 466S; 466C; 466HWS; 468C; 468S; 468HWS; 472C; 472S; 472HWS; 764	F-515	3RG	03616	4	0.399	10.1	Steel; Stainless Steel
42A; 202; 360; 820; 364; 732	E-1032	R1032/S	03532	6	0.450	11.4	Steel; Stainless Steel; Schd 80
466; 468; 472	E-1962	3RGC1	03617	4	0.285	7.2	Cast Iron; Ductile Iron
466C; 466S; 466HWS; 468C; 468S; 468HWS; 472C; 472S; 472HWS	E-3186	R3186	03526	4	0.680	17.3	Steel; Ductile Iron Heavy Wall

## Cutter Wheel Conversions

Manufacturer Cutter No.	Manufacturer Wheel	Reed Cat. No.	Item Code	Std. Pack*	Blade Exposure**		Application
					inches	mm	
<b>ARMSTRONG®</b>							
1T; 2T; 2TA		2RBS	03612	12	0.300	7.6	Steel; Stainless Steel
1T; 2T; 2TA		2RBHD	03613	12	0.296	7.5	HD for Steel; Stainless Steel
4A		3RG	03616	4	0.399	10.1	Steel; Stainless Steel
4A		3RGCI	03617	4	0.285	7.2	Cast Iron; Ductile Iron
<b>GASTITE®</b>							
RT15T1; RT15T3; RT15T2; T15T1; T15T2		0	03660	12	0.180	4.6	Copper; Aluminum; Brass; Steel; CSST
<b>IMPERIAL EASTMAN</b>							
127-F/FA/FB; TC1050; 227-FA	S32633	32633	03661	12	0.127	3.2	Copper; Aluminum; Brass
TC1000; TC1020; 374; 312-FC/FB; 274-FC/FB; 174-F	S75015	75015	03662	12	0.125	3.2	Copper; Aluminum; Brass; Steel
TC1000; TC1020; 374; 312-FC/FB; 274-FC/FB; 174-F	S75046	75046	03663	12	0.125	3.2	Stainless Steel
<b>LENOX®</b>							
21010-TC11/8; 21011-TC13/8; 21012-TC13/4	21017-TCW158C	0	03660	12	0.180	4.6	Copper; Aluminum; Brass; Steel
21010-TC11/8; 21012-TC13/4; 21011-TC13/8; 21013-TC25/8	21015-TCW158SS	OSS	03655	12	0.160	4.1	Brass; Stainless Steel
21013-TC25/8	21016-TCW158P	1-2PVC	04184	12	0.280	7.1	PVC; Plastic
<b>SWAGelok®</b>							
MS-TC-308	MS-TCW-308	OSS	03655	12	0.160	4.1	Stainless Steel
<b>WHEELER REX®</b>							
95041	8050	HS4	03504	4	0.320	8.1	Steel; Stainless Steel
95041	8078	HS4	03504	4	0.320	8.1	Steel; Stainless Steel
95061	8052	HS6	03506	4	0.390	9.9	Steel; Stainless Steel
95081; 95121	8054	HS8-12	03508	4	0.450	11.4	Steel; Stainless Steel
	8002	HX21/2	03510	4	0.383	9.7	Steel; Stainless Steel; Schd 80
95041	8051	HI4	03522	4	0.258	6.6	Cast Iron; Ductile Iron
95061; 95081; 95121	8053	HI6	03524	4	0.410	10.4	Cast Iron; Ductile Iron
95061; 95081; 95121	8076	H6PSE5	03525	4	0.400	10.2	Steel; Cast Iron; Ductile Iron
	8839	RCS8-36	03530	4	0.635	16.1	Steel; Stainless Steel
	8838	RCI8-30	03535	4	0.500	12.7	Cast Iron; Ductile Iron
9590	8001	2RBHD	03613	12	0.296	7.5	HD for Steel; Stainless Steel
	8004	3RG	03616	4	0.399	10.1	Steel; Stainless Steel
	8016	3RG	03616	4	0.399	10.1	Steel; Stainless Steel
9290; 9291	8012	OSS	03655	12	0.160	4.1	Stainless Steel
9290; 9291	8015	0	03660	12	0.180	4.6	Copper; Aluminum; Brass; Steel
	8021	30-40	03665	12	0.250	6.4	Copper; Aluminum; Brass; Steel
9490	8025	30-40	03665	12	0.250	6.4	Copper; Aluminum; Brass; Steel
	8034	345T	03666	12	0.146	3.7	Copper; Aluminum; Brass
	8045	R4546	03668	6	0.161	4.1	Steel; Stainless Steel
90735; 90728; 90750	8071	73505	03690	12	0.170	4.3	Copper; Aluminum; Brass; Steel
	8065	OP2	04180	12	0.275	7.0	ABS; PE; PEX; PP; PEX/AL/PEX
	8036	30-40P	04190	12	0.343	8.7	ABS; PE; PP
	8037	3-6PVC	04194	12	0.377	9.6	3"-6" PVC; 4" Heavy Wall; CPVC

\* Cutter wheels sold to distributors in standard package quantities only.

\*\* Blade Exposure determines wall thickness capacity of cutter wheel.



**Reed has the widest variety of high-quality wheels  
for more cutters and more brands than any other manufacturer!**

